

# Specifications for Residential Overhead Electric Service Installation

This brochure addresses most typical residential overhead service installations. Variances for the following specifications must be approved in advance by Ameren Missouri. For the detailed information, go to <http://www.ameren.com/servicemanual>. If you have any questions, please contact your Ameren Missouri Representative, or call 1-866-992-6619.



## CALL 1-800-344-7483 (DIG RITE) BEFORE DIGGING

*To ensure your new overhead electric service is installed in a safe, reliable and timely manner, the following specifications must be met. Failure to meet any of the requirements may cause a delay in receiving service and/or require the relocation of facilities.*

*Please check with your local inspection authority for any additional requirements before installation.*

## Location for Point of Delivery on Buildings

### NOTES:

1. These guidelines apply to Ameren Missouri only.
2. An approved location for the point of delivery to a customer's premises will normally be within 10' of nearest corner front or side of the home if proper clearance can be maintained to the service connection on the front or side of the home where possible.
3. Distribution point from Ameren System may be overhead or underground. Refer questions to an Ameren representative if recommended location is not feasible.
4. Applicable charges are governed by State tariffs. Contact your local Ameren representative for an explanation of charges that may apply.
5. Meter base shall be securely attached to home 3' to 5' 6" above finished grade from center of the meter. A minimum of 3-1/2' of clear working space shall be provided and maintained in front of all meter and instrument transformer enclosures and 6" above, below, and to each side of the meter equipment, and 6'6" standing headroom. See meter location below for additional details

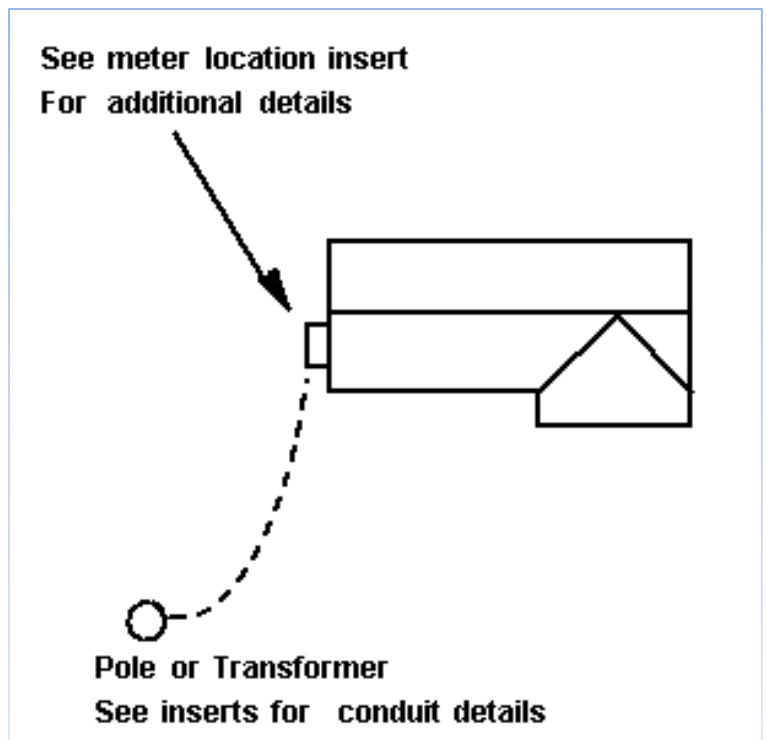

## Meter Location (Refer to Ameren Service Manual 200.01)

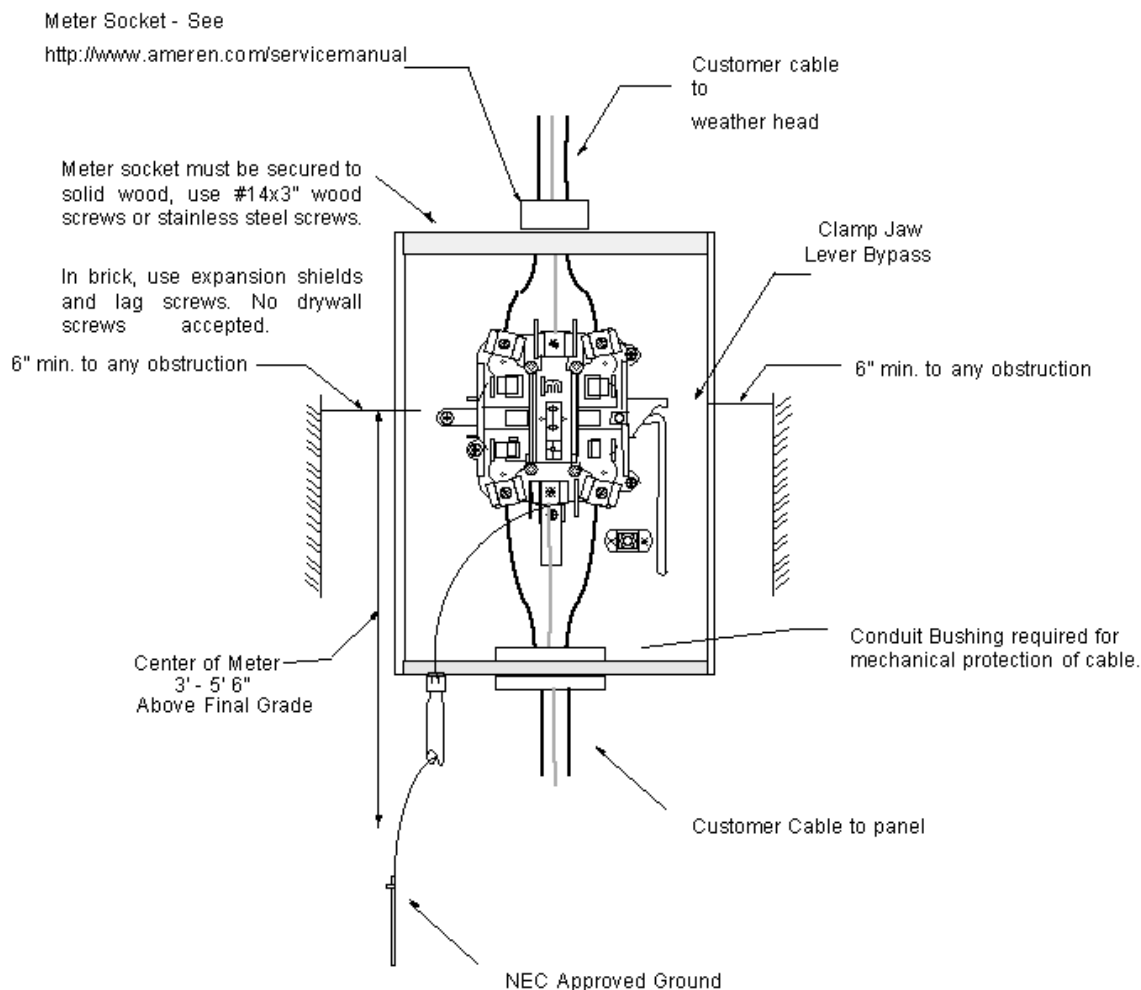

### Note:

1. The customer shall provide a suitable place for the installation of metering equipment.
  - a) The equipment shall be installed on the outside wall of the customer's building or approved metering structure and be so located that adequate space and unobstructed access is provided to the Company's representatives for reading, testing, maintaining and exchanging of such equipment.
  - b) In flood areas, a permanent ladders or stairways shall be provided by the customer to meet OSHA requirements, and meet the latest NEC, at no cost to Ameren, when Ameren's equipment is located on platforms, balconies, mezzanine floors, roofs, or other hard to reach area as specified by Ameren as defined in Section 100 in Ameren Service Manual.
  - c) The customer shall consult the Company regarding the proper location of the equipment.
2. Metering equipment shall not be located on Company owned poles or on buildings adjacent to driveways, alleys, streets or other similar exposed places where it can be damaged by moving vehicles unless the equipment is protected by a substantial guard rail or posts. The customer shall consult the Company representative regarding providing adequate protected barrier.

**Nor shall** any portion of the metering equipment be located below, above, or within:

  - a) 3 feet radius of a gas meter and regulator installation shown Figure 200-4
  - b) 6 feet to any electric motor, generator, belt, or other moving machinery
  - c) Other hazards which would endanger the safety of those reading or working on metering devices.
  - d) Location must also satisfy NEC Article 110.26, clear working space around meter, as described below in 200.01.A.3 and also illustrated in Figure 200-4.

(Continued on next page)

## Meter Location (Continued)

3. Clear working spaces shall not be used for storage.
  - a) A minimum of 3 1/2 feet of clear working space shall be provided in front of all meter and instrument transformer enclosures.
  - b) There shall be a minimum working clearance of 6 inches above, below, and to each side of the metering equipment.
4. Metering equipment shall not be mounted on portable trailers, buildings, mobile home or manufactured (modular) home, recreational trailers, or truck trailers; unless the manufactured (modular) home meets the conditions stated in the latest NEC.
5. Metering equipment must be installed in a workman like manner and firmly attached to the surface on which it is mounted.
6. All locations where metering equipment is installed shall have a minimum standing headroom of 6 feet, 6 inches.

### Meter Location on Side of House (Figure 200-4 in Ameren Service Manual)

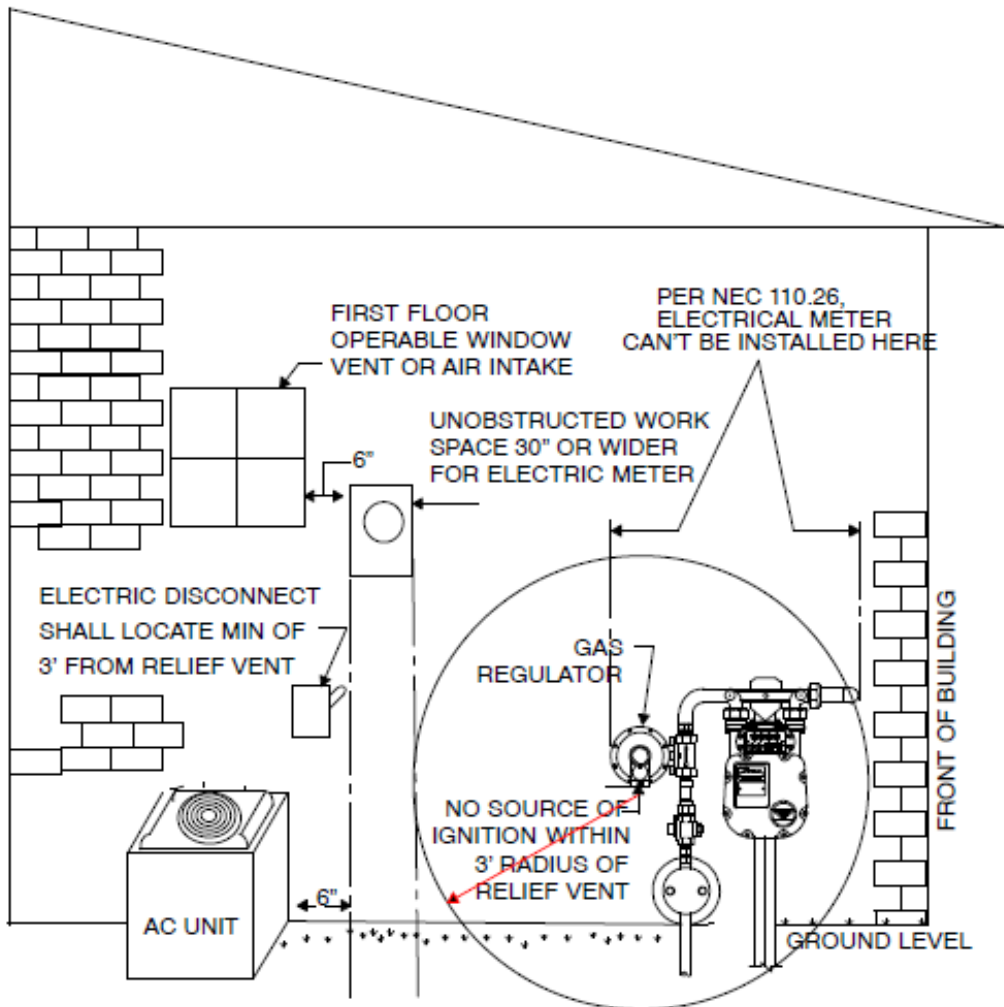

NOTE: METER EQUIPMENT'S LOCATION MUST SATISFY NEC 110.26, BOTH 3' VENT CLEARANCE TO GAS METER, AND 30" WORKING SPACE

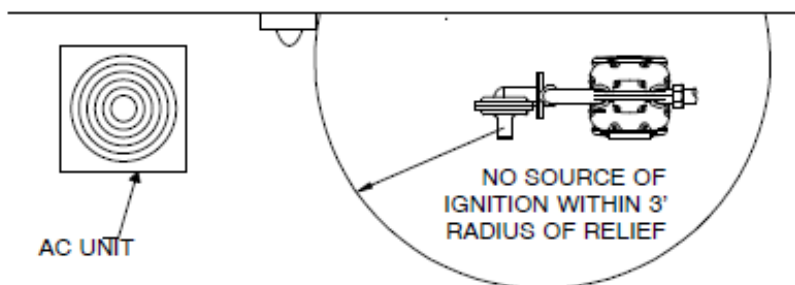

# Overhead Service Installations

(Ameren Service Manual Figure 600-1)

## TYPICAL PERMANENT SERVICE DROP

Figure 600-1

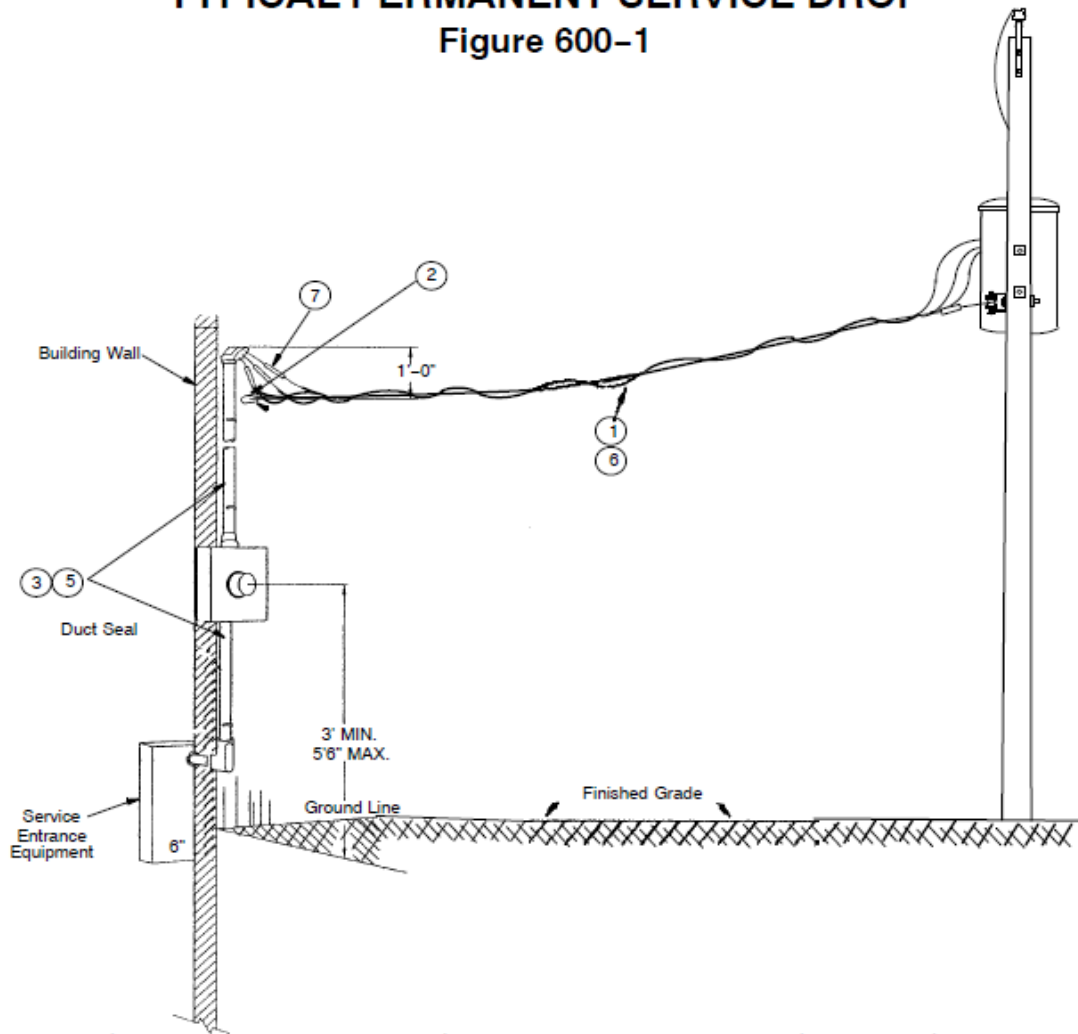

### NOTES:

1. Overhead service drops and the connections at each end of the service drop will be owned, installed, and maintained by Ameren.
2. Customer shall install a service drop attachment of adequate strength for the installation of Ameren service. See Figure 600-2.
3. The weather-head service raceway or conduit, service entrance conductors, grounding electrode system, meter socket, and service entrance equipment will be installed, owned and maintained by the customer. This installation shall meet the requirements of the Authority Having Jurisdiction.
4. Grounding shall meet the requirements of the latest edition of the National Electrical Code (NEC) or the requirements of the Authority Having Jurisdiction.
5. Refer to Section 200 and Figures 200-1, 200-3, and 600-6 within this manual for details regarding the location, installation, and placement of customer owned facilities.
6. For maximum residential service drop length, see Figure 600-2, Note 4. For the maximum lengths of commercial overhead services, contact your local Ameren representative. Large service sizes, uneven grades, or a combination of these may require reduced service lengths or additional poles to maintain the required ground clearances. Additional charges may apply. Clearance requirements are outlined in Section 800 of this manual.
7. Service entrance conductors will extend approximately 3 feet from the weather-head.
8. If the installation is a Current Transformer installation, refer to Section 1001 for additional information.
9. The neutral conductor shall have an outer covering of continuous white or gray with a readily distinguishable colored stripe other than green running along its insulation. The neutral can also be distinguished at the time of installation by white or gray tape encircling the conductor or insulation.
10. If high leg or wild leg is present, this conductor must be marked as orange.



## GROUNDING (Refer to 500.01 Ameren Service Manual)

All **standard services** that operate below 1000 volts as defined in Section 400 shall contain a grounded neutral conductor. A **non-standard** service that operates below 1000 volts as defined in Section 400 may have a grounded phase conductor used as a circuit conductor in the system.

The grounded neutral or grounded phase conductor is earth grounded at the utility transformer and is extended to the self-contained meter socket, meter disconnect, or CT enclosure and to each service disconnect in accordance with the latest edition of the NEC.

For underground systems, the service riser conduit(s) on the supply side of the customer's meter disconnect, self-contained meter socket, or CT enclosure shall not contain the grounding electrode conductor. If a customer chooses to secure/protect the grounding electrode conductor in a conduit, this conduit shall be dedicated solely for this purpose.

Customers requiring an ungrounded service for operations as permitted by the NEC, shall submit an exception request detailing the special circumstances necessitating the request. In addition, the customer shall state in the exception request that they are aware of and accept the increased risks to personal safety associated with an ungrounded service. Customers who receive an ungrounded service from the Company **MUST INSTALL** ground detection sensing equipment. When supplying an ungrounded service results in an additional cost to the Company, this may be passed on to the customer.

For electric service installations where galvanized or EMT metallic conduit is used on the supply side of the service main disconnect, bonded bushings or threaded hubs shall only be used at one end of the conduit to prevent appreciable circulating currents from flowing on the equipment enclosures. An exception to this would be when using metallic conduit for protection of the grounding electrode conductor. In this case, the NEC requires bonding on both ends of this metallic conduit to prevent causing a high impedance path or inductive choke.

## SINGLE-PHASE AND 3-PHASE SELF-CONTAINED METERING LESS THAN 480 VOLTS (Service Manual Figure 500-2 & Figure 500-3)

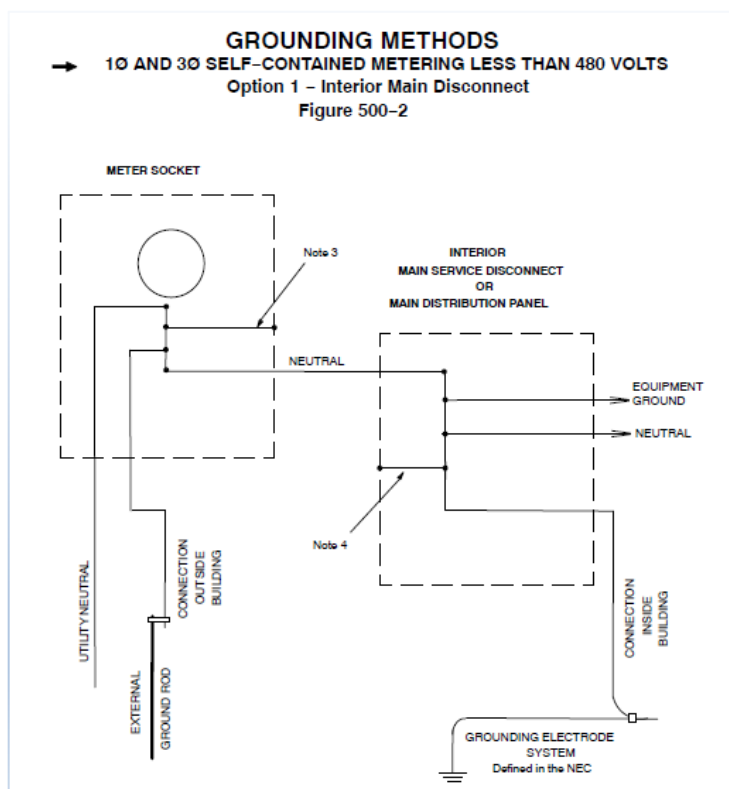

### Notes: (Figure 500-2)

1. Refer to section 500.03.
2. If an external grounding electrode system is connected in an outdoor location at the self-contained meter socket provided by the customer to meet NEC grounding requirements, then this grounding electrode system will also meet Ameren's requirement for an external grounding electrode.
3. Bonding jumper between neutral and case
4. **Main** bonding jumper between neutral and case

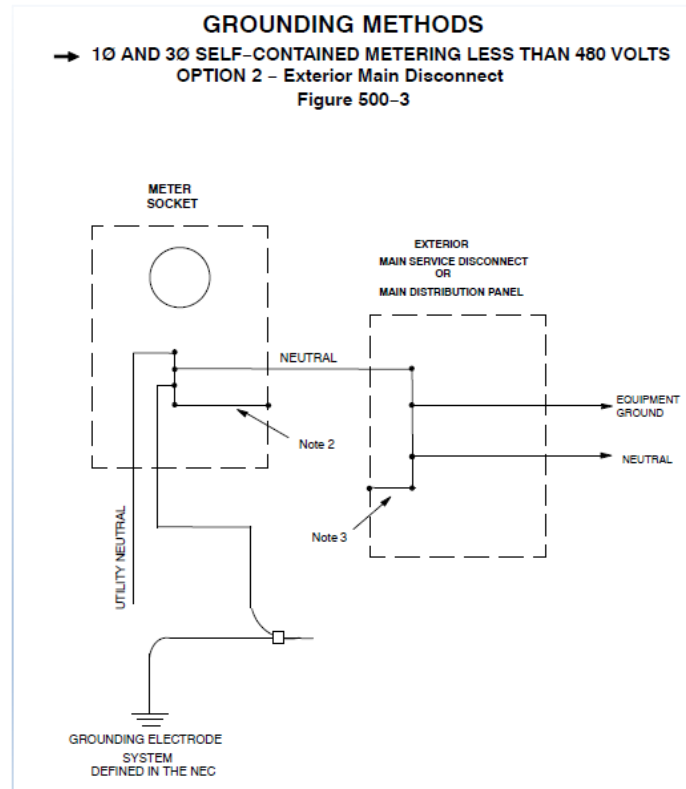

### Notes: (Figure 500-3)

1. Refer to section 500.03
2. Bonding jumper between neutral and case
3. **MAIN** bonding jumper between neutral and case



## GROUND METHOD

(Refer to 500.03 Ameren Service Manual)

1. The grounding method drawings are schematic in nature. Actual wiring details will vary between equipment and manufacturer.
2. The details shown in these drawings are not a substitute for an understanding of the grounding and bonding requirements of the National Electrical Code (NEC) and the requirements of the Authority Having Jurisdiction for the area the work is taking place.
3. Ameren requires an external grounding electrode to be electrically connected to the case and grounded conductor for self-contained meter sockets, meter disconnects, and CT enclosures that are mounted outdoors on most installations.
  - This electrode may act either as the sole or auxiliary electrode for the service equipment associated with the premises. Installation and material used for the Ameren required external grounding electrode must meet all NEC requirements for size, material, and installation. If an external grounding electrode system is connected in an outdoor location at the self-contained meter socket or CT enclosure provided by the customer to meet NEC grounding requirements, then this grounding electrode system will also meet Ameren's requirement for an external grounding electrode.
  - Where other electrodes are available inside a premises, these become the grounding electrode system and **MUST NOT** be connected to the driven outside electrode that terminates within the self-contained meter socket, meter disconnects, or the CT enclosure, **EXCEPT** via the grounded (neutral) conductor. This wiring method will ensure that normal neutral currents **WILL NOT** flow on equipment grounding conductors. This method is allowed by the NEC where certain conditions are met. (Reference the latest NEC 250.142(A), for grounding equipment use of grounded circuit conductor.)
  - Where the customer has a main service disconnect mounted within 10 feet and in sight of the Ameren self-contained meter socket or CT enclosure, connection of an external grounding electrode system to the service equipment disconnect is acceptable in lieu of landing in the utility metering equipment.
4. Exceptions to the grounding methods found in section 500 must be approved by Ameren Engineering prior to construction.

TYPICAL  
INTER-SYSTEM BONDING  
FIGURE 500-1

## Inter-system bonding

(Refer to Figure 500-1)

The National Electrical Code requires in most situations an inter-system bonding termination to be made between the electrical system and other communication/broadband(CATV) systems located external to the main service disconnect, CT enclosure, or self-contained meter socket to minimize the potential differences between equipment of different systems. This inter-system bond shall not be attached to the meter socket, meter socket lid, or CT enclosure.

This connector must be listed for the intended purpose and solidly affixed to the premises wall or other substantial premises structure

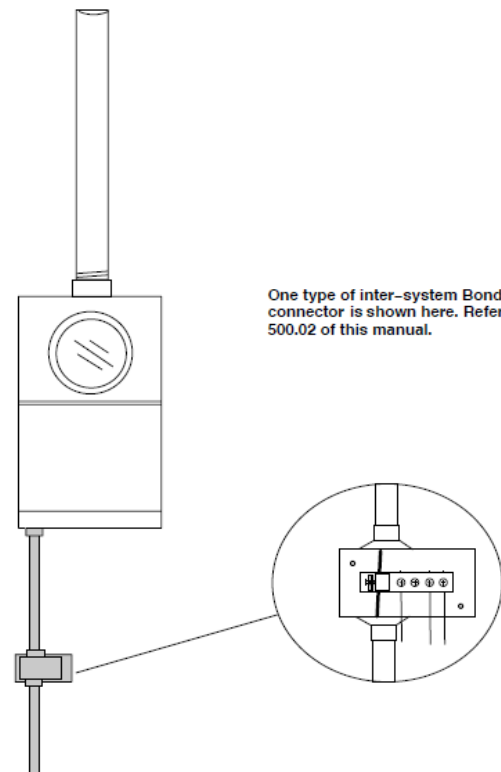

One type of inter-system Bonding connector is shown here. Refer to Section 500.02 of this manual.





**Service Specifications – Overhead Services Attached to buildings**  
 (Service Manual Figure 600-7)

**SERVICE SPECIFICATIONS  
 OVERHEAD SERVICES ATTACHED TO BUILDINGS  
 For Services Under 600 VOLTS  
 Figure 600-7**

ACCEPTABLE POINTS OF ATTACHMENT

- A. BUILDING STUDS
- B. MORTAR JOINTS

UNACCEPTABLE POINTS OF ATTACHMENT

- \* 1. OUTSIDE TRIM BOARD
- \* 2. INSIDE TRIM BOARD (BRICK BUILDINGS)
- \* 3. SOFFIT BOARD
- 4. FASCIA BOARD
- 5. FIRE WALLS, PARAPET WALLS FOR CHIMNEYS

\* MAY BE ATTACHED TO IF ADEQUATELY REINFORCED.

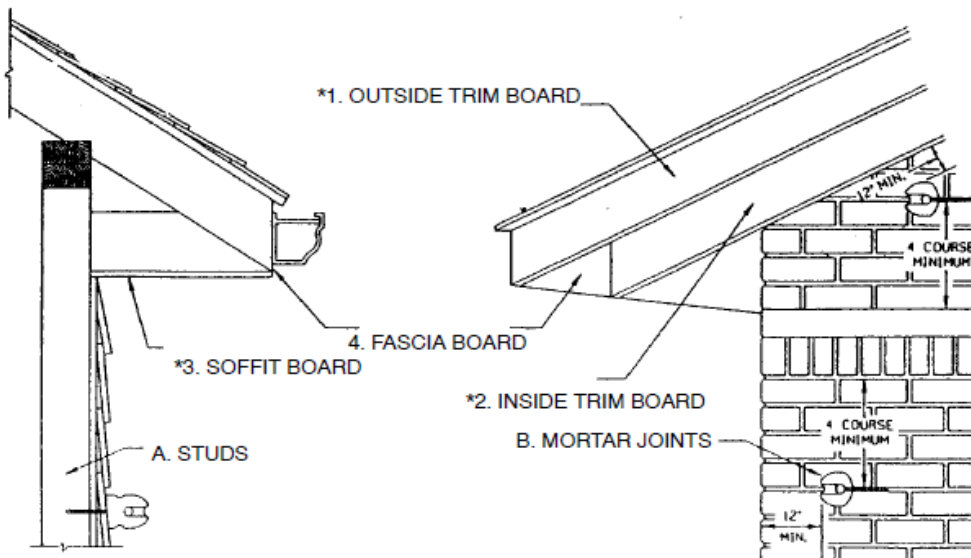

**FIGURE 1**

FRAME-COMPOSITION SHINGLE  
 OR BRICK VENEER CONSTRUCTION

**FIGURE 2**

BRICK OR SOLID MASONRY CONSTRUCTION



# SINGLE PHASE INSTALLATION, 100-320 AMP RESIDENTIAL RISER ON CUSTOMER OWNED POLE (Service Manual Figure 600-5)

## Notes:

1. Service drop conductors, grips and connectors are provided, installed, and owned by Ameren.
2. See Figure 600-2 of Service Manual for maximum length of residential service drop.  
For all other services contact Ameren for maximum service lengths. Reduced distance or higher attachment point may be required for large service or to maintain minimum clearances.
3. Customer installs service drop attachment of adequate strength for attachment of Ameren's service drop conductors. See Section 800 of Service Manual for clearance information.
4. Service entrance conductors can be connected to meter socket terminals by Customer. Service entrance conductors can extend a minimum of 36" or longer if required by local inspector, outside the service head for connection to service drop.
5. Service raceway and service entrance conductors to be owned, maintained, and installed by Customer.
6. Customer's installation to meet the requirements of all applicable local codes as well as the NEC.
7. Grounding shall meet the requirements of the latest edition of the National Electrical Code (NEC) or the requirements of the Authority having Jurisdiction.
8. Insulated conduit bushings are required for raceways terminating in the meter socket.
9. The use of flexible metallic conduit, liquid tight flexible metallic conduit, and liquid tight flexible non-metallic conduit for service entrance raceway is prohibited, unless approved by the local inspecting authority.
10. Clearance required between low point of service cable and finished ground grade; refer to Section 800 of Service Manual.
11. The use of electrical grade schedule 40 or 80 PVC for service mast not supporting service drop is allowed unless prohibited by the local inspecting authority.
12. Customer to provide and install support for service attachment and meter socket.
13. Refer to Section 800 of Service Manual for required clearances.
14. Guy and anchor installed by customer to be used when required holding any unbalanced conductor load which pole cannot sustain.
15. If customer install as a yard light on this pole, such yard light shall maintain a clearance to Ameren Service wires by not less than 24".

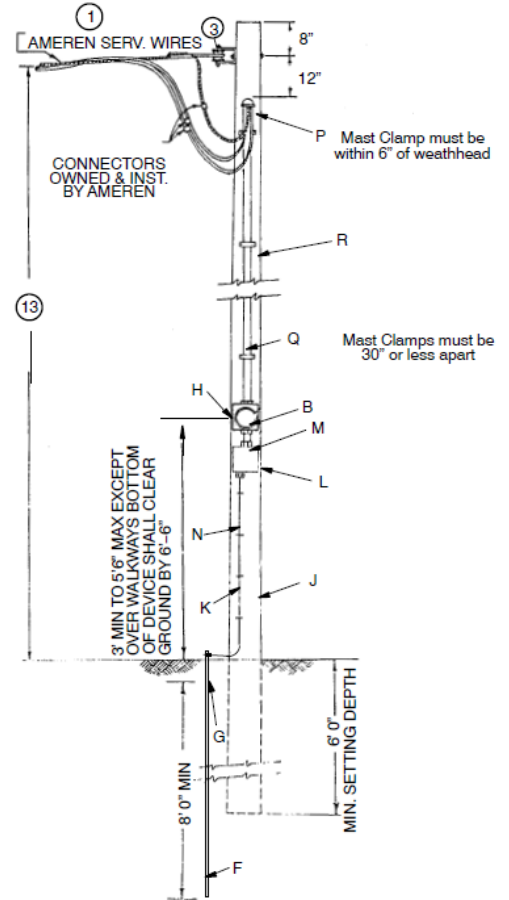

	Description	Req'd
<u>MATERIAL INSTALLED AND OWNED BY AMEREN</u>		
B	Meter	1
<u>MATERIAL INSTALLED AND OWNED BY CUSTOMER</u>		
A	Clevis - Secondary	1
C	Lock nuts	1
D	Insulated Bushings	1
F	Rod - Ground 1/2 in. x 8 ft	1
G	Clamp - Ground 1/2 in.	1
H	Meter Socket, Clamp Jaw Lever Bypass	1
J	Pole, 25 ft Class 5 (Minimum) - New	1
K	Staple	As Req'd
L	Disconnect Device Weatherproof	1
M	Nipple	1
N	Ground Wire	As Req'd
P	Entrance Cap	1
Q	Conduit or Cable	As Req'd
R	Strap - Conductor	As Req'd
(14)	Guy and Anchor	1





# SINGLE PHASE INSTALLATION 120/240 VOLT RESIDENTIAL OVERHEAD SERVICE 100-320 AMP RISER/NON-RISER TYPE

(Service Manual 600-2)

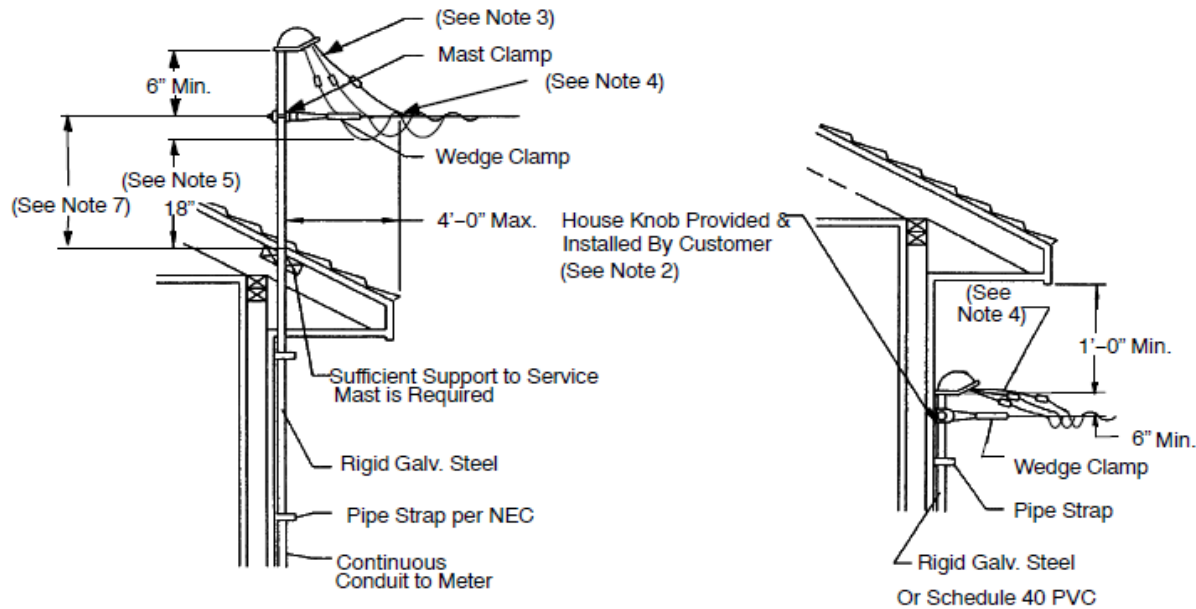

Table 1. Maximum Attachment Height Above Roof (Note 8)

Amperes	Phase	Utility Supplied Service Drop	2 in. Rigid Steel $\varnothing$ Conduit	2 1/2 in. Rigid Steel $\varnothing$ Conduit	3 in. Rigid Steel $\varnothing$ Conduit
100 A	1	#2 Al, Triplex	2 ft 2 in.	4 ft 1 in.	-
200 A	1	#2 Al, Triplex	2 ft 2 in.	4 ft 1 in.	-
200 A	1	1/0 Al Triplex	-	4 ft	-
200 A	3	1/0 Al, Quadruplex	-	4 ft	-
400 A	1	4/0 Al, Triplex	-	-	4 ft
400 A	3	4/0 Al, Quadruplex	-	-	4 ft

## NOTES:

- Before installing electrical facilities, check for compliance with local codes as well as NEC.
- The screw of the knob shall be imbedded at least 2 in. into a vertical stud or masonry of the house. Another acceptable attachment such as clevis, bolt and backing plate may be substituted.
- Approximately 36 in. or longer of conductor will extend from weather-head.
- #2 triplex cable shall not be used where the span length exceeds 140 ft and 1/0 and 4/0 triplex and quadruplex shall not exceed 100 ft.
- 18 in. minimum permitted within 6 ft of service mast, providing voltage between conductors does not exceed 600 volts, the service mast is no more than 4 ft from the edge of the roof, and the service is terminated at the service mast.
- Refer to Section 800 for required clearances.
- Heights greater than shown in Table 1 are possible provided that adequate guying and support are provided and approved by Ameren.
- The conduit size specified are the minimum required for either conduit fill or strength required to support the overhead service, whichever is greater.
- Ranch style homes or buildings with flat roofs may require service masts to provide proper clearance. When through the roof service masts are installed, the customer assumes all responsibility for roof leaks. Service masts must be of adequate strength or be supported by brackets or guy wires to safely withstand the strain imposed by the service drop. The attachment point must have sufficient height to meet clearance requirements.
- The roof support plate provides the main means of support for the mast. It shall be securely lagged to roof rafters. This can be accomplished by reinforcing underneath the roof decking with 2 in. X 6 in. wood material or by utilizing the following manufacturer roof support plate.

<u>Manufacturer</u>	<u>2 in. Conduit</u>	<u>2-1/2 in. Conduit</u>
PPC Insulators	7510	7511



# ALLOWABLE SERVICE POINT ATTACHMENT LOCATIONS

(Service Manual Figure 600-6)

NEW ELECTRIC SERVICE ENTRANCE SHALL BE IN SHADED SPACES NOT LESS THAN 12' NO MORE THAN 18' ABOVE GROUND AND MEET MINIMUM GROUND CLEARANCE.

CLEARANCE  
REFLECT REQUIREMENTS  
OF NEC AND NESC

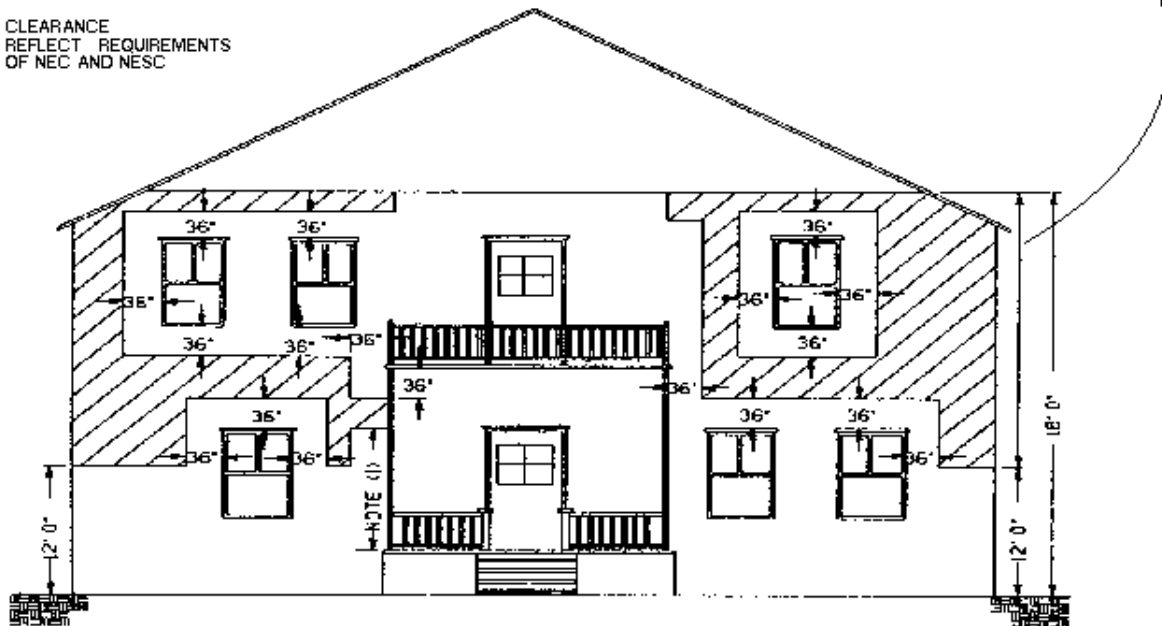

## NOTES: (Ameren Service Manual Figure 600-6)

1. The first point of attachment for service wires shall be in the shaded spaces or higher. The minimum height of attachment shall be adjusted so that the lowest point of the service conductor meets the clearances. A service mast may be used if necessary to obtain the minimum clearances. The point of attachment should be approved by Ameren and should not be located as to limit ladder access, i.e. above a deck, hot tub, spa, stairwell, or swimming pool.
2. The customer's service weatherhead shall not be located above 18', but it may be necessary to attach services higher than 18' to meet the minimum ground clearances.
3. Triplex cable or separate open wire service busses on buildings shall be placed in the shaded spaces shown.
4. Service conductors passing by doors, porches, fire escapes or similar locations, shall have a clearance of not less than 36 inches. Service conductors passing by windows shall have a clearance of not less than 36 inches.
5. Service conductors shall not be installed beneath openings through which materials may be moved, such as openings in farm and commercial buildings. Overhead wires shall not be run such that they obstruct entrance to these building openings.
6. For minimum required clearance of services over sheds, garages, swimming pools, hot tubs, spas, etc., please refer to the latest NEC and NESC.



## MATERIALS TO BE FURNISHED & INSTALLED BY CUSTOMER

**Meter Socket** – Less than or equal to 320 amp service continuous rating: Clamp jaw bypass.

To get the latest catalog number information for the meter sockets, please use the website as indicated below. (Note: **Ameren Missouri only accepts meter mounting devices from the list, and if failure to comply the requirements may delay service until requirement is met.**)

<http://www.ameren.com/servicemanual>

### CUSTOMER CHECKLIST

- Correct type & size meter base installed? (see material list for details)
- Meter socket properly installed? (securely fastened to wall, an approved location for the point of delivery to a customer's premises which is between the midpoints of building from the corner nearest the company's distribution system, 3.0' to 5' 6" above finished grade)
- Permanent unobstructed work space left in front of meter socket? (minimum 3 1/2' of clear working space in front of meter and 6" above, below, and to each side of the meter equipment, 6' 6" standing headroom)
- Clear work area required around the Ameren Missouri pole and or secondary where the overhead service will attach.
- Customer wiring completed and inspected as necessary?
- Cost arrangements made and easements provided? (as required)

Ameren Missouri Work Request No: \_\_\_\_\_

Engineering Contact: Phone: \_\_\_\_\_

Construction Contact: Phone: \_\_\_\_\_

***Thank you for letting Ameren Missouri serve your energy needs.***

