



**Callaway**  
Energy Center

**SWPM**

**SAFE WORK PRACTICES MANUAL**

**MINOR Revision 027**

**Check Variances for changes to the Safe Work Practices Manual between revisions!**

***Variances are located on the Safety Home Web Page under  
"Active Variances to the Safe Work Practices Manual"***

## SAFE WORK PRACTICES MANUAL

### TABLE OF CONTENTS

Section	Page Number
<b>CALLAWAY ENERGY CENTER PERSONNEL SAFETY POLICY.....</b>	<b>6</b>
Mission Statement .....	6
Implementing Objectives.....	6
RULES TO LIVE BY.....	6
<b>INTRODUCTION.....</b>	<b>7</b>
Purpose of the Safe Work Practices Manual.....	7
Safe Work Practices Principle/Hierarchy of Controls.....	7
Employee Observation Responsibility .....	7
Revisions to the Safe Work Practices Manual .....	7
Requests for a Variance of a Safe Work Practice .....	8
Stopping Unsafe Work .....	8
Safe Work Practices Tools / Energy Wheel.....	8
High Energy Hazards and Definitions.....	9
<b>SAFETY CONCERNS.....</b>	<b>11</b>
Immediate Safety Concerns .....	11
Handling Immediate Safety Concerns.....	11
Non-Immediate Safety Concerns .....	11
Safety Concerns that Do Not Allow a Job to be Worked .....	11
Medical Emergency Response Team (MERT) & Fire Brigade.....	12

**SAFE WORK PRACTICES MANUAL**

**TABLE OF CONTENTS**

Section	Page Number
<b>ABRASIVE BLASTING.....</b>	<b>13</b>
<b>ABRASIVE WHEELS AND TOOLS .....</b>	<b>15</b>
<b>ASBESTOS CONTAINING MATERIALS .....</b>	<b>16</b>
<b>AERIAL WORK PLATFORMS.....</b>	<b>17</b>
<b>BARRICADE TAPES, SAFETY SIGNS AND DANGER TAGS.....</b>	<b>18</b>
<b>BLOODBORNE PATHOGENS.....</b>	<b>21</b>
<b>CHEMICAL HAZARDS .....</b>	<b>22</b>
<b>COLD STRESS / WINTER SAFETY .....</b>	<b>23</b>
<b>CORROSIVES/ACIDS/OXIDIZERS .....</b>	<b>25</b>
<b>COMPRESSED AIR.....</b>	<b>28</b>
<b>COMPRESSED GASES .....</b>	<b>29</b>
<b>CONCRETE CORE DRILLING/CONCRETE CUTTING .....</b>	<b>32</b>
<b>CONFINED SPACES .....</b>	<b>33</b>
<b>CRANES LIFTING AND RIGGING.....</b>	<b>34</b>
<b>DIVING OPERATIONS.....</b>	<b>35</b>
<b>ELECTRIC EXTENSION CORDS/FLEXIBLE CORDS, CABLES, AND OUTLETS.....</b>	<b>36</b>
<b>ERGONOMIC WORKSTATION SET UP .....</b>	<b>39</b>
<b>EXCAVATION SAFETY .....</b>	<b>40</b>
<b>EYEWASH STATIONS/SHOWERS.....</b>	<b>41</b>
<b>FALL PROTECTION/ELEVATED AREAS .....</b>	<b>42</b>
<b>FIRE PREVENTION/PROTECTION.....</b>	<b>60</b>
<b>FORKLIFTS .....</b>	<b>61</b>
<b>HAND AND PORTABLE POWER TOOLS .....</b>	<b>63</b>
<b>HAZARDOUS ATMOSPHERES .....</b>	<b>64</b>

**SAFE WORK PRACTICES MANUAL**

**TABLE OF CONTENTS**

Section	Page Number
<b>HEAT STRESS .....</b>	<b>66</b>
<b>HEXAVALENT CHROMIUM .....</b>	<b>67</b>
<b>HYDROLASING/WATER BLASTING EQUIPMENT (3000 PSI OR GREATER) .....</b>	<b>68</b>
<b>JOB SAFETY BRIEFINGS.....</b>	<b>69</b>
<b>LABORATORY SAFETY.....</b>	<b>70</b>
<b>LADDERS .....</b>	<b>71</b>
<b>LEAD .....</b>	<b>73</b>
<b>RAD FLEX AND HIGH DENSITY LEADED ELASTOMER (HDLE) PENETRATION SEALS COMPLIANCE PLAN.....</b>	<b>74</b>
<b>LEGIONELLA BACTERIA .....</b>	<b>76</b>
<b>MANUAL MATERIAL HANDLING (LIFTING AND BACK SAFETY).....</b>	<b>77</b>
<b>OFFICE SAFETY.....</b>	<b>78</b>
<b>PERSONAL PROTECTIVE EQUIPMENT (PPE).....</b>	<b>79</b>
<b>POWERED EQUIPMENT OPERATION.....</b>	<b>87</b>
<b>RADIO FREQUENCY HAZARDS (RF).....</b>	<b>88</b>
<b>RADIOLOGICAL SAFETY .....</b>	<b>89</b>
<b>REPORTING OF INJURIES AND ACCIDENT/INCIDENT .....</b>	<b>90</b>
<b>RESPIRABLE CRYSTALLINE SILICA CONTAINING MATERIALS .....</b>	<b>91</b>
<b>RESPIRATORY PROTECTION.....</b>	<b>92</b>
<b>SAFETY MEETING GUIDELINES AND SAFETY COMMITTEE GUIDELINES .....</b>	<b>94</b>
<b>SAFETY STAND DOWNS.....</b>	<b>95</b>
<b>SCAFFOLDING .....</b>	<b>96</b>
<b>SHOP SAFETY .....</b>	<b>98</b>
<b>STANDING ON/STEPPING ON PLANT EQUIPMENT.....</b>	<b>99</b>
<b>TOOL/MATERIAL CONTROL ON ELEVATED WORK AREAS .....</b>	<b>100</b>

**SAFE WORK PRACTICES MANUAL**

**TABLE OF CONTENTS**

Section	Page Number
<b>VEHICLE SAFETY.....</b>	<b>102</b>
<b>WEATHER .....</b>	<b>104</b>
<b>WORKMAN'S PROTECTION AND FACILITIES LOCK-OUT.....</b>	<b>108</b>

## SAFE WORK PRACTICES MANUAL

### CALLAWAY ENERGY CENTER PERSONNEL SAFETY POLICY

#### Mission Statement

Successful operation of Callaway Energy Center is founded on our belief that the safety and health of Ameren employees, supplemental employees, and visitors rank in importance with nuclear safety, radiological safety, quality, and cost. The benefits of a safe work place and safe work practices extend far beyond monetary savings. We recognize and accept that the avoidance of injury is a responsibility that impacts our quality of life as well as that of our families and associates.

#### Implementing Objectives

Our goal is to prevent all accidents.

Safety Programs will be the same for everyone, at a minimum, and will be easy to understand and apply.

Each employee's acceptance of responsibility for his or her own safety and the safety of others, including those they supervise, is a continuous requirement.

If an accident/injury occurs, it will be thoroughly investigated to determine root causes and actions will be taken to provide barriers to ensure similar instances do not happen again.

Personnel will be trained in the hazards of their work, safe work practices, and established safety programs to minimize their risk of injury.

In addition to safety rules, common sense, judgment, and concern about the safety of others must be used to implement safe work practices.

Appropriate safety behavioral concepts will be incorporated into all aspects of our work.

#### RULES TO LIVE BY

**Use Fall Protection:** Use proper fall protection when working 6 feet or closer to an unprotected side or edge that is 4 feet or greater to a lower level.

**Adhere to Workers Protection Assurance and/or Facilities Lockout Program:** Do not violate a hold-off tag, a Personal Hold-Off Device (PHOD) or any facilities lock out device.

**Adhere to Electrical Safety Requirements:** Do not violate personal protective equipment requirements for arc flash boundary and/or restricted approach boundary as identified in the Electrical Safe Work Practices Manual (ESWPM).

**Adhere to Confined Space Entry Requirements:** Do not enter a confined space where atmospheric monitoring has not been performed.

**Avoid Walking Under Suspended Load:** Do not walk (or stand) under a suspended load.

If a Rules to Live By Violation is observed:

1. Immediately stop the job.
2. Contact the individual's supervisor and advise them of the situation.
3. Supervisor should begin fact-finding.
4. Supervisor should inform the Safety Department.

## INTRODUCTION

### Purpose of the Safe Work Practices Manual

To provide consistent safe work practices for personnel at the Callaway Energy Center.

While the safe work practices in this manual should eliminate duplicate safety directives and procedures from various departments, they are not intended to replace specific safety and health programs (e.g. Confined Space Entry Program, Workman's Protection); but rather to complement these programs.

### Safe Work Practices Principle/Hierarchy of Controls

Whenever practical, eliminate hazards by changing the work process or by substituting a less hazardous component. When it is impractical to eliminate the hazard, safeguard it using the practices outlined in this manual. If no specific practices are identified for safeguarding the hazard, use the work planning process to evaluate the hazard and to specify appropriate precautions. Never rely on personal protective equipment alone to prevent an injury. Personal protective equipment is used as a back up to established safeguards only as the last line of defense against injury.

The hierarchy of controls is a tool that can help implement feasible and effective hazard control solutions to reduce injuries and illnesses. The most effective means of hazard control is always elimination if it is possible. Work down the hierarchy of controls with PPE being the last line of defense.

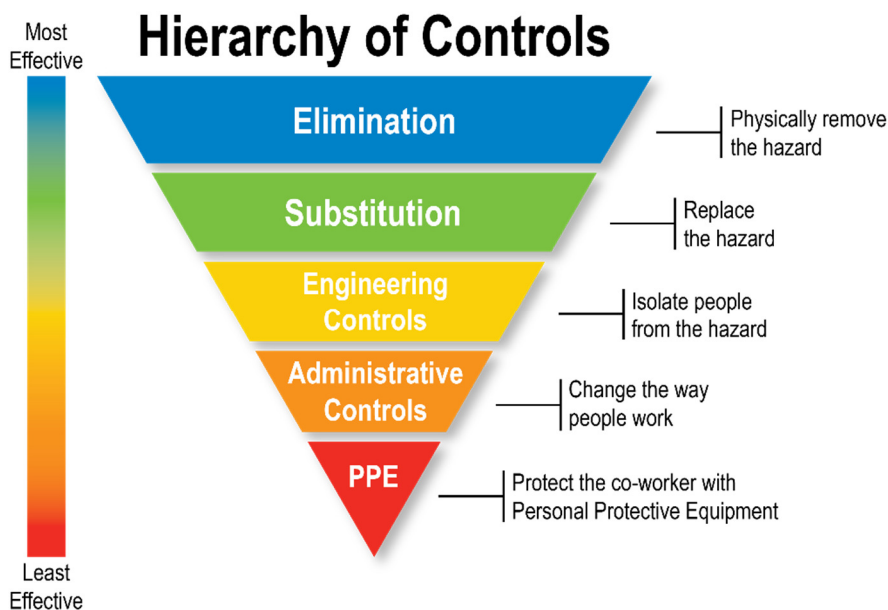

### Employee Observation Responsibility

When a violation of a Safe Work Practice is observed by any Employee, the Employee SHOULD immediately discuss the infraction with the employees involved and assist them in correcting the infraction. Any follow up actions are the responsibility of the individual's supervisor.

### Revisions to the Safe Work Practices Manual

Efforts have been made to make this manual clear and easy to understand. However, we recognize changes will need to be made from time to time. Condition Reports (CR) are available for personnel to use when submitting safety suggestions for improvement or changes to the manual.

### Requests for a Variance of a Safe Work Practice

Efforts must be made to meet the requirements of the Safe Work Practices Manual. If a situation arises and all options have been evaluated and no solution is available, a Request for a Variance of a Safe Work Practice Form CA2380 may be initiated. The Variance may be temporary or may remain in effect until the next revision of the Safe Work Practices Manual. A listing of Variances will be maintained on the Safety Department Webpage.

### Stopping Unsafe Work

Everyone has the right and responsibility to question the safety of work activities and to stop work that has a probability of resulting in injury or illness. Resolution should begin with the identifying individual and the Work Supervisor and additional assistance may be requested. Ultimately it is the Work Supervisor's responsibility, along with the workers performing the work, to ensure the work is performed safely. If any employee feels their safety concern has not been adequately addressed, they should take the concern to the next level of management.

### Safe Work Practices Tools / Energy Wheel

The energy wheel provides co-workers with a simple and systematic approach to energy identification (hazards). It provides a visual prompt for consistent examination of energy-based hazards and to recognize hazards as potential events. The Energy Wheel should be used during pre-job briefs, two-minute drills, and any time hazard identification is required.

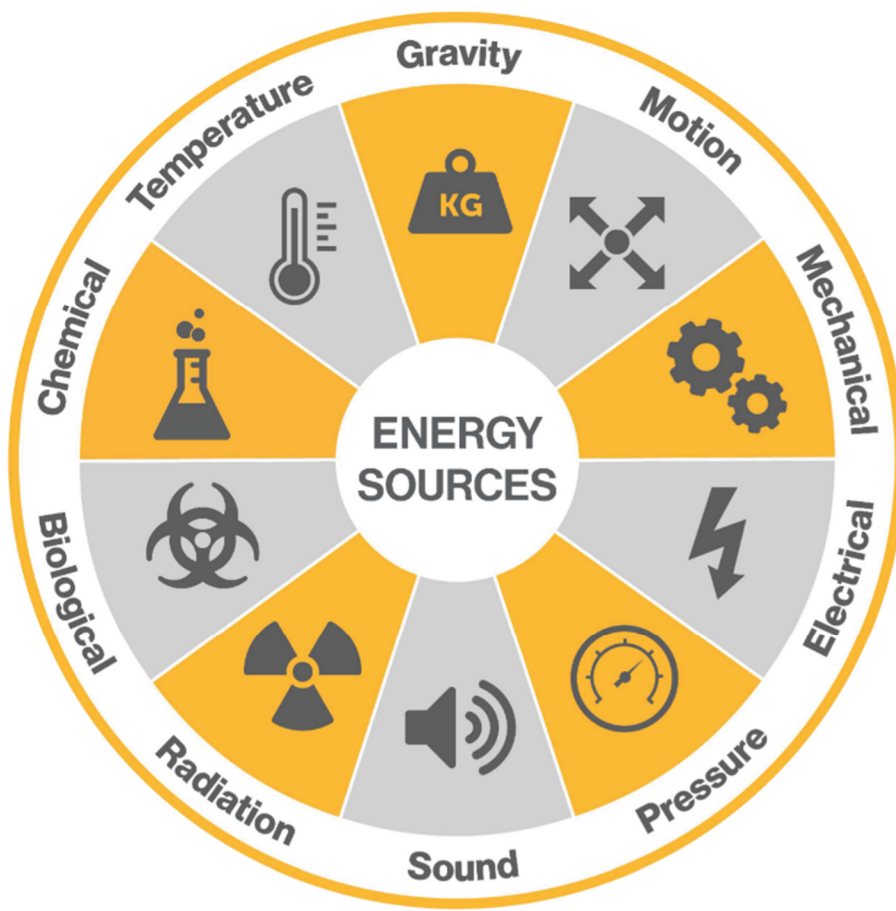

## High Energy Hazards and Definitions

It is generally accepted that exposure to an element of work that involves more than 1500 joules of physical energy is considered a High Energy Hazard. Contact with this amount of energy has the potential to cause severe injury or death. Typical hazards of this nature that may be encountered in the electric generation industry and other nuclear facilities include:

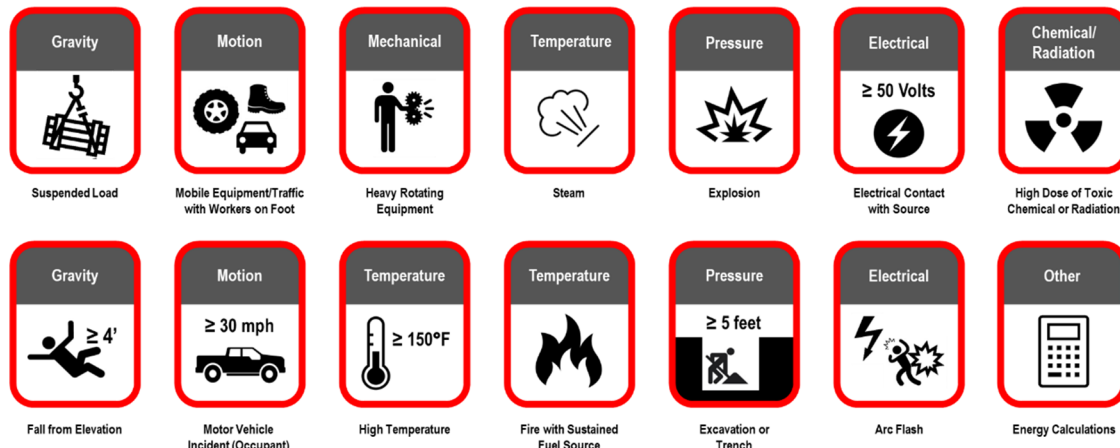

- Gravity – Suspended Loads
- Motion – Vehicle or Equipment traffic near workers on foot.
- Mechanical – Computing mechanical energy can be complex, as it requires estimates of the moment of inertia and angular velocity for rotating objects and stiffness and displacement for tension or compression. Thus, all heavy rotating equipment beyond powered hand tools typically exceeds the high energy threshold and should be considered high energy.
- Steam – According to the American Burn Association, any circumstance with the release of steam exceeds the high energy threshold.
- Explosion – Most incidents described as an explosion exceed the high energy threshold.
- Electrical Contact – Electricity equal to or exceeding 50 volts is sufficient to result in serious injury or death.
- Chemical/Radiation High Doses – Exposure to toxic chemicals, or radiation. An industrial hygienist, chemist, or toxicologist should be involved in the assessment of toxicity and acceptable exposure limits. These hazards are considered life threatening hazards. For example, exposure above the accepted carbon monoxide threshold 50ppm is immediately dangerous to life/health (IDLH); therefore, for the purposes of this SOER would be considered life threatening hazard.
- Working from height – Considering the average weight of a human is over 68 kg (150 lbs.), 1.2 meters (4 feet) 150 lbs. of elevation (measured from the ground surface to the bottom of the feet) exceeds the high energy threshold.
- High Temperature – According to the American Burn Association, exposure to any substance greater than or equal to 66 degrees Celsius (150 degrees Fahrenheit) typically causes third degree burns when contacted for two seconds or more.
- Excavation/Trench – An exposure to unsupported soil in a trench or excavation that exceeds 1.5 meters (5 feet) of height exceeds the high energy threshold. Typically, for each 30 centimeters (1 foot) 5 feet) of depth, the pressure is approximately 0.1 bar (200 psf).

- Arc Flash – Any arc flash exceeds the high energy threshold because of the voltage exposure.
- Other Items to consider are:
  - Drowning Hazard – Process of experiencing respiratory impairment from submersion/immersion in liquid.
  - Hot/Cold Environment – Conditions that impact the body’s ability to regulate body temperature such as hypothermia (freezing temperatures) or hyperthermia (heat stress/stroke).
  - Confined Spaces or Oxygen Deficiency – Work inside of a permit required confined space or an area that could become oxygen deficient.

## **SAFETY CONCERNS**

### **Immediate Safety Concerns**

Definition: An immediate safety concern is a safety concern that has a high potential of resulting in the injury of an employee the day the concern is noted.

### **Handling Immediate Safety Concerns**

When an Immediate Safety Concern is identified, the discovering employee or their supervisor will perform the following:

Address the immediate concern as soon as reasonably possible.

1. The actions may include such things as:
  - a. Fixing or eliminating the hazard
  - b. Taking the equipment out of service, if applicable
  - c. Barricade the area to ensure personnel will not be injured
  - d. Initiating a job and notifying the Shift Manager of the concern and requested actions.
2. Generate a CR for all Immediate Safety Concerns.

#### **NOTE**

Once action is taken to address the Immediate Safety Concern and the hazard is reduced or protected, resolution will be addressed in the normal course of business for any safety concern that is noted.

All items that meet the definition of "Immediate Safety Concern" are to be e-mailed using the address in the email of "@CAL Immediate Safety Concerns". This will ensure items are documented and addressed.

A direct link can be found on the Callaway Energy Center Intranet Home Page under the Safety heading. Click on the Immediate Safety Concern bullet which will open an email window with the correct address.

### **Non-Immediate Safety Concerns**

1. All non-immediate Safety Concerns are to be addressed in the normal course of our business.
2. Safety Concerns receive priority to reduce the potential for injury to employees.
3. This may include....
  - a. Immediately taking action to address the concern
  - b. Initiation of a "Condition Report PER APA-ZZ-00500"
  - c. RFR, or JOB
  - d. By some other means.

### **Safety Concerns that Do Not Allow a Job to be Worked**

When a safety concern arises with a job that causes the job to be delayed or not worked, that concern is to be 'flagged' on the work document and actions taken to evaluate and, if necessary, solve the safety issue prior to completing the job. The person who originally brought up the concern is to be notified of the resolution of the safety concern by their supervisor. (CR 199901134). Additionally, safety hazards that may be repetitive for a particular job or component may be documented in EMPRV under Safety Concerns.

### **Medical Emergency Response Team (MERT) & Fire Brigade**

Due to Operations legal procedural requirements, the Fire Brigade cannot respond for rescue situations outside the OCA fence.

For work activities that require fire brigade rescue plans outside the OCA fence, prior arrangements must be made with Operations. Examples of work activities that could require fire brigade rescue include but are not limited to confined space entry, working at heights with fall protection, etc. For confined space non-entry rescue, outside the OCA, utilize approved non-specialized equipment such as winches, lines, and an adequate number of personnel to safely perform a non-entry rescue based on the confined space and conditions. If a rescue plan would require rescue personnel to rig or perform other specialized rescue procedures, work activities requiring these plans will not be conducted until such time as properly trained personnel are available for support.

During times of Security minimum staffing, mostly on nights and weekends, our Medical Emergency Response Team (MERT) is not available for response to the river intake or outside the OCA for medical emergencies. If high risk work activities are planned for work outside the OCA, verification must be obtained through the Security Shift Supervisor (SSS) that staffing exists to support a MERT call prior to beginning work, or currently qualified CPR and First Aid personnel must be present during work activities. Supervisors and work groups need to work together to ensure adequate plans are in place and personnel are available to support high risk work activities at the river intake or outside the OCA prior to the start of work.

#### **References:**

CR 201202531

**ABRASIVE BLASTING**

Intent	Provide guidance for the use of abrasive blasting that will reduce the risk of injury
Applicability	Applies to abrasive blasting activities at Callaway
Hazards	Struck by – Inhalation – Explosion – Particles in eye – Sound levels – Slip/Trip

**Key Point**

Dusty environments can create many potential hazardous atmospheres. Special precautions may be necessary based on the work scope. Industrial Hygiene guidance should be consulted if there are questions or concerns about atmospheres created by abrasive blasting.

**General Safe Work Practices**

1. Inspect abrasive blasting machines and hoses prior to use and replace all parts showing excessive wear.
2. Follow the compressed air section of the Safe Work Practices Manual (SWPM) for hose connection hook up.
3. Use cleaning nozzles equipped with an operating valve which must be held open manually or remote control “dead man” valve on blasting hose. Electric “dead man” (if utilized) shall be low voltage (12 volt DC) and have continuous wire or plug connections provided.
4. Contact Ameren Industrial Hygiene for guidance on exhaust systems when toxic, flammable or explosive dust mixtures may be present.
5. Only use compressed air for cleaning objects and materials when the pressure is reduced to less than 30 PSI and when safety goggles and a face shield are utilized.
6. Do not use compressed air for cleaning clothes being worn on skin.
7. Utilize Vortex tubes that cool air supplies to the blasters hood or other approved methods to monitor or control heat stress in temperatures exceeding 90 degrees.
8. Do not allow dust to accumulate on the floor or ledges outside of an abrasive blasting enclosure. Clean areas each shift or more often as conditions warrant.
9. Clear walking and working surfaces of blasting materials that could cause slipping hazards.

**Dust Control Methods**

1. Isolation
  - a. Establish an abrasive blasting zone (where dust is visible) using caution tape in accordance with Barricade Tapes, Safety Signs and Danger Tags section of the SWPM. Caution signs should state: CAUTION-Abrasive Blasting Area, Standard PPE, Hearing Protection and Respirator required.
  - b. Do not perform abrasive blasting operations when wind direction and velocity carry visible dust to people unprotected by a proper respirator.
2. Enclosures
  - a. Pre-Manufactured
    - 1) Perform abrasive blasting operations in a pre-manufactured abrasive blasting enclosure in accordance with manufactures instructions.
  - b. Erected/Site Specific Enclosures
    - 1) Contact Ameren Industrial Hygiene for assistance with exhaust design assistance during planning phases of work activities. ANSI Z9.2-1960 and ANSI Z33.1-1961 set the requirements for exhaust systems.

### Step 2.b Cont'd

- 2) Maintain exhaust ventilation in such a way that continuous inward flow of air will be sustained at all openings in the enclosure during abrasive blasting operations.
  - 3) Arrange or baffle all air inlets and access openings so that by the combination of inward air flow and baffling the escape of abrasive dust into adjacent work areas will be minimized and visible spurts of dust will not be observed.
  - 4) Ensure the rate of exhaust inside the enclosure is sufficient to provide prompt clearance of the dust-laden air within the enclosure after abrasive blast is ceased.
  - 5) Do not open enclosures until exhausting system has had sufficient time to remove dusty air within the enclosure.
  - 6) Repair enclosure leaks when dust is observed escaping.
  - 7) Check and clean the system when static pressure drops at exhaust ducts indicate partial blockage of the system.
  - 8) Exhaust air from blast-cleaning equipment through dust collecting equipment.
  - 9) Set up dust collectors so they can be emptied and removed without contaminating other work areas.
3. Respiratory Protection
- a. Use respirator and respiratory equipment in accordance with the Respiratory Protection section of the SWPM.
  - b. Contact Ameren Industrial Hygiene for assistance in performing hazard assessments of respiratory concerns or health considerations that may be produced by the course of work.
  - c. Do not consider “dust masks” as respiratory protection.
  - d. Wear an abrasive-blasting hood at all times when inside an abrasive blasting enclosure during blasting operations.
  - e. If abrasive blasting operations have ceased and airborne dust levels have subsided, a proper ½ face respirator may be worn for non-blasting work or inspection inside the area of the enclosure.

### References:

None

**ABRASIVE WHEELS AND TOOLS**

Intent	Prevent injuries associated with the use of abrasive wheels, grinders, wire wheels, and other grinding tools.
Applicability	Applies to all work activities that involve the use of abrasive wheels and grinders.
Hazards	Cuts – Pinch Points – Eye/face Hazards – Structural Failure – Hand Hazards – Entanglement

**Key Point**

Only operate abrasive wheels and tools in accordance with manufacturer recommendations /instructions (i.e. only operate with guards in place, etc.)

**General Requirements**

1. When operating abrasive wheels and tools, follow the Personnel Protective Equipment (PPE) requirements listed in the PPE section of the Safe Work Practices Manual (SWPM).
2. Only personnel trained and qualified on the maintenance and operation of abrasive wheels and tools are allowed to operate them.
3. Only operate abrasive wheels and tools in accordance with procedures or manufacturer recommendations/instructions (i.e. only operate with guards in place, etc.).
4. Portable grinder wheels must be enclosed with a substantial guard to protect the operator if the wheel breaks. Exceptions include:
  - a. Wheels used for internal work.
  - b. Wheels used in portable operations 2” or smaller in diameter.

**References:**

29CFR1910.215, Abrasive Wheel Machinery  
29CFR1926.303, Abrasive Wheels and Tools

**ASBESTOS CONTAINING MATERIALS**

Intent	Reduce the potential for exposure to asbestos containing materials to no more than .1 fibers/cc 8 hour time weighted average.
Applicability	Applies to all work activities that involve the use of asbestos containing materials.
Hazards	Asbestos Exposure

**Key Point**

Working with Asbestos Containing Materials always requires special work practices to reduce the potential of inhalation of fibers.

For all information concerning asbestos refer to APA-ZZ-00834, Asbestos Control Program.

**References:**

APA-ZZ-00834 – Asbestos Control Program

29CFR1910.1001, Asbestos

29CFR1926.1101, Asbestos

ES-REG-203 – Asbestos Exposure Controls & Work Practices

**AERIAL WORK PLATFORMS**

Intent	Provide guidance to eliminate the hazards associated with working on an aerial work platform.
Applicability	Employees – Vendors – Contractors
Hazards	Fall

**General Requirements**

1. Aerial work platforms (AWP) are powered platforms and include, but are not limited to, JLG’s, Fork Truck Personnel Lifts, Bucket Trucks, and Mobile Scissors Lifts.
2. Only trained individuals shall operate aerial work platforms.
3. Operate Aerial Work Platforms in conjunction with the manufacturer’s operating manual.
4. Follow the PPE requirements listed in the PPE section of the Safe Work Practices Manual (SWPM).
5. Do not exceed the manufacturer’s rated load capacity.
6. Personnel must utilize fall protection equipment when working in AWP with exception of Scissor Lifts and one-man lifts when allowed by manufacturer instructions.
7. AWP cannot be used as fall protection tie-offs for work outside the platform unless designed for that use and authorized by the manufacturer.
8. Never tie off to an adjacent pole, structure, or piece of equipment when working in an AWP.
9. Only exit an AWP while elevated, if the platform has been positioned over and within one foot of a safe and secure structure. Fall protection rules and regulations apply.
10. Never position an AWP platform against another object to steady it.
11. When elevating, always do so on a firm level surface or with slope limits described by the manufacturer.
12. Employees shall always stand firmly on the floor of the basket and shall not sit or climb on the edge of the basket or use planks, ladders, or other devices for a work platform.
13. Any Aerial Work Platform with a vertical reach capability of 50 feet or greater entering a “Crane Restriction Zones” must follow the direction in APA-ZZ-00365, Callaway Energy Center Lifting and Rigging Program ADDENDUM L Crane Operations Near Energized Equipment.
14. Do not walk under an Aerial Lift boom while work is being performed.
15. Do not park the Aerial Lift with the boom raised.
16. If the Aerial Lift boom must be parked in the raised position, put barricade around the area under the boom.
17. If storms are in the area, follow the guidance in APA-ZZ-00365 Add L for Storms and Tornado Warnings.

**References:**

- American National Standard for each type of Aerial Work Platform
- Tool/Material Control on Elevated Work Areas section of SWPM
- 29 CFR 1926.451 – Scaffolds General Requirements
- 29 CFR 1926.453 – Aerial Lifts
- APA-ZZ-00365 – Callaway Energy Center Lifting and Rigging Program

**BARRICADE TAPES, SAFETY SIGNS AND DANGER TAGS**

Intent	To provide a means to prevent accidental injury or illness to employees who may be exposed to hazards.
Applicability	All personnel exposed to hazards
Hazards	Various

**Key Point**

YELLOW barricade tape and CAUTION SIGNS are for hazards that can hurt you. RED barricade tape, DANGER SIGNS, and DANGER DO NOT USE TAGS are for hazards that **CAN KILL YOU**.

**General Information**

1. Barricade tape needs to be installed considering the weather conditions that may cause the tape to fall or come loose. Tape should be installed in a manner that it will stay up until removed.
2. All barricade tape must be tagged or marked indicating the reason it is placed and the contact information for the responsible person. Yellow caution tape may be used to denote trip and bump hazards without a required sign or tag as long as the marked hazard is obvious, and the Hierarchy of Controls is utilized.
3. Barricade tape should be installed to barricade a hazardous area and not just in the most convenient manner. If necessary to lessen the impact of a barricade, stanchions should be used to better define a hazard boundary (e.g. When barricading temporary power cables if the area can be barricaded using stanchions and barricade tape so as to allow foot traffic to pass by safely then that would be the desired method).
4. Tapes and signs cannot provide conflicting messages (e.g. caution signs placed on white tape).
5. Signs must be installed with hazard information facing the direction of approach.

**RED Barricade Tape**

RED Barricade Tape must be used to warn personnel of immediate hazards that present a threat of death or serious injury and must be used to designate the arc flash boundary or limited approach boundary during electrical work. Red Tape is used **WHEN** spotters cannot control the entire AFB or LAB.

1. RED Barricade Tape Controls
  - a. RED Barricade Tape may be installed by any plant employee provided the following actions are taken:
    - 1) The hazard has been determined to be an immediate hazard that could cause death or serious injury.
    - 2) The Shift Manager/Operating Supervisor (SM/CRS) is contacted and informed of the hazard and that the RED Barricade Tape will be installed.
  - b. Personnel who cross RED Barricade Tape must:
    - 1) Ensure the SM/CRS has been notified that RED Barricade Tape will be crossed. Advise the SM/OS if multiple entries are expected on the same shift. The SM/CRS may only require one notification per shift. If the job extends through a shift change, the oncoming crew must also call the SM/CRS.
    - 2) If a person is working alone and must cross RED Barricade Tape and no other personnel are in the immediate area, the SM/CRS must be advised of the entry including an estimated time the activity will take. The individual must notify the SM/OS after leaving the area barricaded with RED Barricade Tape.

### Step 1.b Cont'd

- 3) RED Barricade Tape is removed by the work group who has eliminated the hazard. When RED Barricade Tape is removed, the SM/CRS must be notified.

### **YELLOW Barricade Tape**

YELLOW Barricade Tape must be used to warn personnel of immediate hazards that have the potential to cause injury but are not life threatening.

1. YELLOW Barricade Tape Controls
  - a. YELLOW Barricade Tape may be installed by any plant employee provided the following actions are taken:
  - b. The hazard has been determined to have the potential to cause injury but is not life threatening.
  - c. Personnel should not cross YELLOW Barricade Tape unless they are aware of the hazard and have a business need to cross it (e.g. need to enter the area to perform a work activity). Shorter travel path is not considered a valid need to cross.
  - d. YELLOW Barricade Tape may be removed by any plant employee when the hazard or potential hazard has been eliminated.

### **ORANGE Barricade Tape**

ORANGE Barricade Tape must be used for concerns other than personnel hazards such as:

- Limiting access to sensitive plant equipment during mid loop or lowered inventory operations or plant startup.
- Limiting access to a job site to limit interruptions or distractions.
- Painting activities

1. ORANGE Barricade Tape Controls
  - a. ORANGE Barricade Tape may be installed by any plant employee with the approval of their Supervisor.
  - b. The SM/CRS must be notified when ORANGE Barricade Tape will be left in place with no personnel associated with the job present.
  - c. Personnel should not cross ORANGE Barricade Tape unless they are aware of why it has been installed and have permission from the work group who installed it or the SM/CRS.
  - d. ORANGE Barricade Tape may be removed by any plant employee once its purpose is complete.

### **White Barricade Tape**

WHITE Barricade Tape is to be used to indicate and define a lay-down area for supplies, parts, tools, or other equipment associated with maintenance, modifications, or refuel projects.

1. WHITE Barricade Tape Controls
  - a. White barricade tape can be installed by any employee with the approval of their supervisor.

**NOTE**

White rope may be used when conditions require (such as windy areas). The appropriate tape must be wrapped around the rope to clearly identify the hazard area, and signs must be attached.

**SAFETY SIGNS**

Safety signs are normally used to inform personnel of possible and existing hazards. Some of these signs such as Notice and Warning may be used for things other than safety. There are four types of signs: Danger (white with a red header), Caution (yellow with a black header), Warning (orange with a black header), and Notice (white with a blue header).

**Danger Signs (CA2994)**

Use danger signs in long term major hazard situations where an immediate hazard presents a threat of death or serious injury. Examples include high voltage, fall hazards, or asbestos work.

**Notice Signs**

Notice signs are used to inform personnel of potential hazards. These hazards would not normally be present but be brought about by changes in the area. Examples include labeling an area to indicate storage of compressed gases or chemicals that could become a hazard, give directions, locations, or emergency action.

**Warning Signs**

Warning signs are used to inform personnel of potential hazards that would not normally be present but could arise through improper handling or operations by personnel. Examples include equipment warning on prohibited operations of equipment, restriction on a system line up that could cause a hazard, or the use of chemicals in certain processes such as using an oxidizer in the presence of a flammable substance.

**Caution Signs (CA2995)**

Use caution signs for short or long-term hazard situations where a non-immediate hazard or situations is of a lesser threat of injury. Examples include storage of combustible material, increased personal protective requirements because of a local hazard or work process, excavations, or spill of hazardous material.

**DANGER DO NOT USE TAG**

DANGER DO NOT USE TAG (CA2504) is used on NON-PLANT equipment only. Examples are equipment such as extension cords, copiers, computer hardware, overhead projectors, etc.

1. The tag is to be filled out by the person finding the hazard and must have the following information on it:
  - a. Description of the hazard in as much detail as is necessary to ensure that the personnel understand the hazard.
  - b. Action taken to correct the hazard such as Work Request Number or information that a request was sent to the appropriate department requesting repair.
  - c. Your name and phone number.
2. Attach the tag to the plug, control switch, or other prominent location so that it is easily seen by personnel who would operate the equipment.
3. Inform the department responsible for the equipment of the hazard and what action you have taken.

**References:**

None

**BLOODBORNE PATHOGENS**

Intent	Prevent exposures to bloodborne pathogens.
Applicability	Applies to all work activities that involve exposure to human body fluids.
Hazards	Exposure to Hepatitis B – HIV – Other Bloodborne Pathogens

**Key Point**

All blood or other body fluids must be treated as if they are infectious. Only trained personnel may clean up bloodborne pathogens in accordance with DDP-ZZ-03001, Control of Exposures to Bloodborne Pathogens.

**Universal Precautions**

1. Only trained personnel may clean-up bloodborne pathogens in accordance with DDP-ZZ-03001.
2. If there is a possibility of contact with blood or body fluids containing blood, wear disposable gloves. If gloves are not immediately available, use several layers of gauze, or other clean material, plastic wrap or bags to stop the bleeding until gloves can be obtained.
3. Ensure the area is barricaded to prevent unanticipated exposure to plant employees.
4. Wash hands with soap and water as soon as practical after gloves are removed or when skin has come in contact with blood or body fluids containing blood. Alcohol should be used if water is not available.
5. You should use a protective mask when administering CPR.
6. Handle waste generated while giving first aid in the following manner:
  - a. Any material used to stop bleeding which can ordinarily be put in the sanitary sewer may be disposed of in that manner.
  - b. All other materials contaminated with blood or body fluids containing blood must be bagged and taken to the Site Nurses office for disposal.

**References:**

DDP-ZZ-03001, Control of Exposures to Bloodborne Pathogens

**CHEMICAL HAZARDS**

Intent	Reduce the potential for injuries and illness associated with hazardous chemicals/substances.
Applicability	Applies to all work activities that present workers with the potential for contact with chemicals.
Hazards	Burns – Spills – Respiratory – Explosion – Poison – Combustible – Trauma Acute/Chronic Illness

**Key Point**

Many chemicals can burn, blind, or cause illness. Consult specific Hazardous Material Permits and Safety Data Sheets (SDS) for specific hazards and requirements per APA-ZZ-00831, Hazardous Material Control Program.

**General Statement:**

1. When working with chemicals we must always err to the conservative.
2. Guidance given for hazardous chemicals/substances is based on good industrial hygiene practices.
3. Information provided here is general in nature.
4. Consult specific Hazardous Material Permits and Material Safety Data Sheets for specific hazards and requirements per APA-ZZ-00831.
5. This information is located in the EMPRV System and Safety1Source.
6. Contact Safety or Chemistry for additional assistance.

**General Safe Work Practices**

1. Before starting work, identify ALL hazardous substances involved with the work task.
2. Follow the PPE requirements listed in the HAZMAT Permit.

**CAUTION**

When breaching a chemical system, contact Chemistry for additional safety and personal protective equipment requirements.

3. If, while wearing chemical suits, gloves, or other equipment, it is suspected that the equipment came into contact with a chemical, contact Chemistry for proper disposal method.
4. Based on the chemical hazard determined from the HAZMAT permit and the SDS, verify a working emergency eyewashes and/or emergency shower in the area before starting work.
5. See section of this SWPM for Emergency Eyewashes and Emergency Showers. If still unsure of the emergency eyewash and/or emergency shower requirements, contact Safety or Chemistry.

**References:**

None

**COLD STRESS / WINTER SAFETY**

Intent	Provide guidance to prevent and/or reduce the probability of a cold related injury/illness.
Applicability	Applies to all workers performing work in cold environments and hazardous winter conditions.
Hazards	Hypothermia – Frost Bite – Frost Nip – Trench Foot – Falls – Vehicle Incidents

**Definitions**

1. **Frost Bite** – Body tissues freeze, most commonly occurring in the hands and feet. It can occur in temperatures above freezing. Symptoms include numbness, reddened skin developing gray/white patches, blistering, and discoloration.
2. **Hypothermia** – The core body temperature falling below 95°F or less. Symptoms include shivering in mild cases, shivering stopping in moderate to severe cases, confusion, slurred speech, reduced heart rate and breathing, loss of consciousness, death.
3. **Traction Devices** – Footwear or footwear accessories designed to increase traction on snow and ice (eg. Yak Traks, spikes, grips, etc.)
4. **Trench Foot** – Non-freezing injury to the foot caused by lengthy exposure to wet and cold environments. Symptoms include redness, swelling, numbness, and blisters.
5. **Wind Chill** – The “feels like” temperature to human skin due to the combination of cold temperatures and winds. The greater the wind chill the faster heat is removed from the body.

**General Safe Work Practices**

1. Temperatures below 40° F should be considered a potential cold stress environment.
2. Cold stress disorders include but are not limited to Hypothermia and Frostbite.
3. Individuals shall immediately exit a cold environment if any cold stress symptoms are present and notify their supervisor and the Control Room.
4. A heated warming shelter should be considered for all continuous work in conditions that are equal to 20° F or below.
5. Continuous exposure of exposed skin should not be permitted when the wind chill is equal to -25° F or below. Wind chill is the combination of air temperature and wind speed (See Wind Chill Chart).

**Encountering Hazardous Conditions**

1. Pathways cleared of snow and/or ice shall be used when available.
2. Pathways or other surfaces covered with snow and/or ice that must be walked on to support work activities should be reported so they can be properly treated and cleared prior to proceeding with the task.
3. If clearing and treating a pathway prior to performing the task is not a viable option (ex. Alarm response, emergent priority activity) then traction devices should be worn.
4. Traction devices shall not be worn inside buildings.
5. Any co-worker can mitigate slip/trip hazards creating an immediate safety concern.

6. When operating a vehicle in snow/ice conditions, reduce speed to ensure control of the vehicle is maintained.
7. Ensure snow/ice is removed from the vehicle windshield and all other areas obstructing the vehicle operator's field of view.
8. Ameren vehicles being operated on public roads shall be free from snow/ice that could become a hazard to other vehicles.

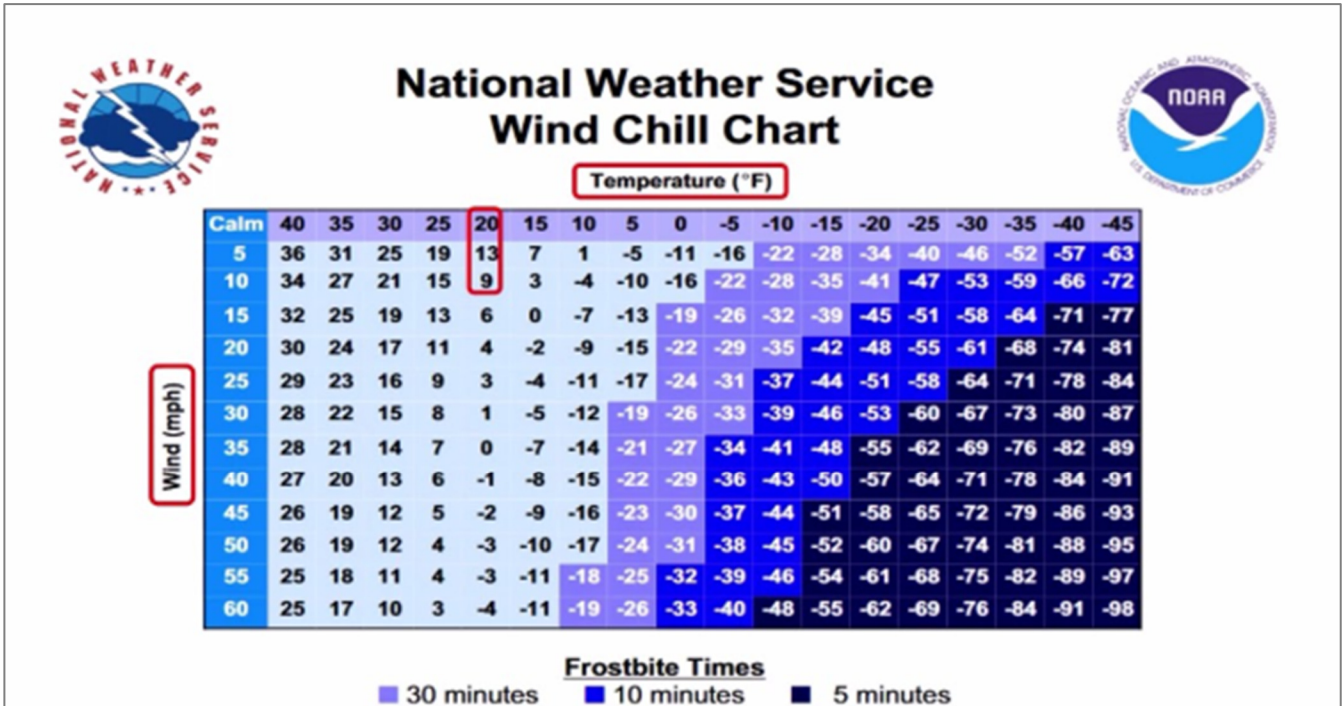

**References:**

National Weather Service Wind Chill Chart

## CORROSIVES/ACIDS/OXIDIZERS

### NOTE

Not all HAZMAT Permits and SDS's have eyewash and/or shower requirements.

When receiving corrosive / acid bulk chemical deliveries or other activities where there is potential for exposure from contact or splash to large quantities of corrosives/acids is possible then one of the following is required:

1. An installed working emergency eyewash and shower, or
2. Sufficient portable emergency eyewash units with drench hose, or equivalent, to supply 15 minutes of continuous flow

When working with or transferring small quantities of corrosive / acidic chemicals not under pressure an emergency eyewash is required at a minimum. When working on vehicle batteries, an eyewash flush bottle must be taken to the job site. When working on sealed batteries (defined as a cell or battery that has no provision for adding water or electrolyte or for external measurement of electrolyte specific gravity) there are no requirements for emergency eyewash.

### Spill Response (*EIP-ZZ-03010*)

### NOTE

EIP-ZZ-03010, Hazardous Chemical/Oil Spill Response/Spill Cleanup is the governing procedure.

1. If during a work activity any chemical is spilled in any quantity, the work should halt while the spill is evaluated, and a plan is made to clean up the spill.
2. If a spill is noticed which you feel may present a personnel hazard or which may require special clean up technique or additional personnel, contact the Control Room Supervisor and stand by to ensure other personnel who may be in the area do not inadvertently walk into the spill area. Position yourself so the fumes or other aspects of the spill do not affect you. Once a spill response team has arrived, you may leave the area.
3. Prior to performing spill cleanup, the Chemistry Department and/or Safety Department must specify personal protective equipment for spill clean-up depending on the material and the particular hazards associated with the spill.

### Chemical Storage

### NOTE

Some chemicals, such as Hydrazine, may cause spontaneous combustion if not treated and disposed of properly.

Hazardous chemical storage information can be found on the chemical label or on the Hazmat Permit.

1. For flammable chemical storage requirements, refer to APA-ZZ-00741.
2. For non-flammable chemical storage requirements, refer to APA-ZZ-00831 and following the below basic guidelines:
  - a. Store acids in separate approved storage locations away from caustics, separate by type.

**Step 2 Cont'd**

- b. Store oxidizers in separate approved storage locations away from flammables.
- c. Store caustics in separate approved storage locations away from acids, separate by type.
- d. Store Reducers in separate storage locations away from oxidizers.
- e. Store Isolates in separate storage locations away from other chemicals.

The following listing is provided to give personnel an idea of the chemicals that are normally added to plant systems. Be aware that other chemicals are added, and this listing will not be all inclusive. If questions arise, contact Chemistry for specifics.

Condensate Chemical Addition AQ	60% Ethanolamine (Permit # 7034) and 35% Hydrazine (Permit # 5963)
Aux Steam Chemical Addition AE/FE	5% Ammonia Hydroxide (Permit # 5962) and 5% Hydrazine (Permit # 5963)
Potable Water Addition KD	5% Sodium Hypochlorite (Permit # 5241)
Polisher Region AK	50% Sodium Hydroxide (Permit # 5707) and 93% Sulfuric Acid (Permit # 7060)
Demin Region AN	50% Sodium Hydroxide (Permit # 5707) and 93% Sulfuric Acid (Permit # 7060)
Circ and Service DA	93% Sulfuric Acid, (Permit # 7060) 12% Sodium Hypochlorite (Permit # 6279) HEDP (BULAB 7016) (Permit #7293) Phosphoric Acid (BULAB 9051) (Permit #7696) Sodium Tolytriazole (BULAB 9027) (Permit # 7114) Biopenetrant (BULAB 8006) (Permit #6335)
Circ and Service DD	12% Sodium Hypochlorite (Permit #6279) Bulab 5013 (Permit # 7112)
Water Treatment DE	12% Sodium Hypochlorite (Permit # 5241)
Radwaste HC	50% Sodium Hydroxide (Permit #5707)

**Quick Reference to NFPA 704 Identification System**

**Health Hazard (Blue)**

4 - Lethal  
3 - Can cause serious or permanent injuries  
2 - Can cause temporary incapacitation or residual injuries  
1 - Can cause significant irritation  
0 - No hazard beyond ordinary combustible materials

**Fire Hazard/Flash Points (Red)**

4 - Below 73°  
3 - Below 100°  
2 - Below 200°  
1 - Above 200°  
0 - Will not burn

**Reactivity (Yellow):**

4 - May Detonate  
3 - Shock & Heat may detonate  
2 - Violent chemical change  
1 - Unstable if heated  
0 - Stable

**Specific Hazard (White):**

None - No specific hazard  
W - Reacts with water  
OX - Material possesses oxidizing properties  
SA - Simple asphyxiant

NAME: This is the actual name of the product  
STOCK NUMBER:PERMIT: This is the stock number from the Material Control System. This is the unique # assigned to this product for this application.

**Categories:**

Category 1 – SPECIAL Use ONLY as specified in Hazmat Permit









Category 2 – UNIVERSAL May be used on ALL plant piping

Category 3 – LIMITED May be used on all plant piping EXCEPT nickel alloy/stainless steel

Category 4 – RESTRICTED MUST NOT be used on plant piping

**Hazard Communication Standard (HCS) Labels and Pictograms**

**HCS Pictograms and Hazards**

<p><b>Health Hazard</b></p>  <ul style="list-style-type: none"> <li>• Carcinogen</li> <li>• Mutagenicity</li> <li>• Reproductive Toxicity</li> <li>• Respiratory Sensitizer</li> <li>• Target Organ Toxicity</li> <li>• Aspiration Toxicity</li> </ul>	<p><b>Flame</b></p>  <ul style="list-style-type: none"> <li>• Flammables</li> <li>• Pyrophorics</li> <li>• Self-Heating</li> <li>• Emits Flammable Gas</li> <li>• Self-Reactives</li> <li>• Organic Peroxides</li> </ul>	<p><b>Exclamation Mark</b></p>  <ul style="list-style-type: none"> <li>• Irritant (skin and eye)</li> <li>• Skin Sensitizer</li> <li>• Acute Toxicity (harmful)</li> <li>• Narcotic Effects</li> <li>• Respiratory Tract Irritant</li> <li>• Hazardous to Ozone Layer (Non-Mandatory)</li> </ul>
<p><b>Gas Cylinder</b></p>  <ul style="list-style-type: none"> <li>• Gases Under Pressure</li> </ul>	<p><b>Corrosion</b></p>  <ul style="list-style-type: none"> <li>• Skin Corrosion/ Burns</li> <li>• Eye Damage</li> <li>• Corrosive to Metals</li> </ul>	<p><b>Exploding Bomb</b></p>  <ul style="list-style-type: none"> <li>• Explosives</li> <li>• Self-Reactives</li> <li>• Organic Peroxides</li> </ul>
<p><b>Flame Over Circle</b></p>  <ul style="list-style-type: none"> <li>• Oxidizers</li> </ul>	<p><b>Environment (Non-Mandatory)</b></p>  <ul style="list-style-type: none"> <li>• Aquatic Toxicity</li> </ul>	<p><b>Skull and Crossbones</b></p>  <ul style="list-style-type: none"> <li>• Acute Toxicity (fatal or toxic)</li> </ul>

**SAMPLE LABEL**

**PRODUCT IDENTIFIER**  
 CODE \_\_\_\_\_  
 Product Name \_\_\_\_\_

**SUPPLIER IDENTIFICATION**  
 Company Name \_\_\_\_\_  
 Street Address \_\_\_\_\_  
 City \_\_\_\_\_ State \_\_\_\_\_  
 Postal Code \_\_\_\_\_ Country \_\_\_\_\_  
 Emergency Phone Number \_\_\_\_\_

**HAZARD PICTOGRAMS**  

**SIGNAL WORD**  
**Danger**

**HAZARD STATEMENT**  
**Highly flammable liquid and vapor.**  
**May cause liver and kidney damage.**

**SUPPLEMENTAL INFORMATION**  
**Directions for use**  
 \_\_\_\_\_  
 \_\_\_\_\_  
 \_\_\_\_\_  
 Fill weight: \_\_\_\_\_ Lot Number \_\_\_\_\_  
 Gross weight: \_\_\_\_\_ Fill Date: \_\_\_\_\_  
 Expiration Date: \_\_\_\_\_

**PRECAUTIONARY STATEMENTS**  
 Keep container tightly closed. Store in cool, well ventilated place that is locked.  
 Keep away from heat/sparks/open flame. No smoking.  
 Only use non-sparking tools.  
 Use explosion-proof electrical equipment.  
 Take precautionary measure against static discharge.  
 Ground and bond container and receiving equipment.  
 Do not breathe vapors.  
 Wear Protective gloves.  
 Do not eat, drink or smoke when using this product.  
 Wash hands thoroughly after handling.  
 Dispose of in accordance with local, regional, national, international regulations as specified.  
**In Case of Fire:** use dry chemical (BC) or Carbon dioxide (CO<sub>2</sub>) fire extinguisher to extinguish.  
**First Aid**  
 If exposed call Poison Center.  
 If on skin (on hair): Take off immediately any contaminated clothing. Rinse skin with water.

**References:**

29CFR1910, Subpart G, Occupational Health and Environmental Control

29CFR1910, Subpart H, Hazardous Materials

29CFR1910, Subpart I, Personal Protective Equipment

29CFR1910, Subpart Z, Toxic and Hazardous Substances

29CFR1910.269.V.7, Chemical Cleaning of Boilers and Pressure Vessels

APA-ZZ-00741; Control of Combustible Materials

APA-ZZ-00831, Hazardous Material Control Program

APA-ZZ-00802, Confined Space Entry Program

EIP-ZZ-03010, Hazardous Chemical/Oil Spill Response Implementing Procedure

WSP-ZZ-00003, Storeroom Material Receiving

CR 199700701

CR 199701264

CR 200000402

CR 200001762

**COMPRESSED AIR**

Intent	Reduce the potential for injuries associated with the use of compressed air.
Applicability	Applies to all work activities that involve the use of compressed air.
Hazards	Striking Hazards – Cuts – Structural Failure

**Key Point**

Compressed Air can blow particles into your eyes or body. Compressed air released uncontrolled from a hose can make the hose a whip that can strike people, can cause people to fall, and damage equipment.

**General Safe Work Practices**

1. Do not apply compressed air to any part of the body. Serious injury can occur.
2. Follow the PPE requirements listed in the PPE section of the SWPM.
3. Compressed air shall not be used for cleaning purposes unless reduced to less than 30 psi and then only when precautions have been taken to protect the operator and any other personnel from the hazards associated with chips and flying debris and adequate personal protective equipment is used. Prior to using compressed air to clean large areas, refer to form CA2479. (CR 199901843)
4. Have a safety device at the source supply to reduce pressure in case of hose failure for hoses exceeding ½”, unless it is necessary for the equipment to perform properly (such as grit blasting, large air impact wrenches, and Wachs pipe machining tools). If the safety device cannot be used, the equipment must be connected with a lanyard or wired together to keep them from separating should the fittings come apart. This does not apply to breathing air systems.
5. Before operating an air hose, examine the connections to ensure they are tight.
6. Inspect hoses for cuts or abrasions prior to use. Defective hoses should be tagged with a “DANGER - Do Not Use” tag.
7. Never use oxygen as a substitute for compressed air.
8. Do not kink air hoses to stop airflow. Always use the control valve.
9. Route hoses in a manner that will minimize their becoming a tripping hazard and will minimize the potential for the hose to be damaged. Normally, route hoses at least seven feet overhead, or under grating, or along the edges of the walls.
10. Use Hansen type fittings for compressed air ONLY.

**Chicago Fittings**

The use of Chicago Fittings for high pressure air applications is strongly discouraged. It is the intent of Ameren Missouri at Callaway Energy Center that Chicago Fittings should not be used on Ameren Missouri owned equipment unless it is necessary for the equipment to perform properly (such as in the use of some type of jack hammers). If Chicago Fittings are used for high pressure air applications, they must be used under the conditions listed below:

- They must be pinned or wired prior to pressurization.
- The hoses must be connected with a lanyard or wired together to keep them from separating if the Chicago Fitting were to come apart.

**References:**

29CFR1910.242, Hand and Portable Powered Tools and Equipment  
CR199901843

**COMPRESSED GASES**

Intent	Reduce the probability of accidents and injuries associated with Compressed gases and compressed gas cylinders.
Applicability	Applies to all work activities that involve the use of compressed gas cylinders. Also contains specific requirements for the handling of Dewar Flasks.
Hazards	Cylinder Missile hazards – Falling Cylinders – Atmospheric Hazard Associated with Gases – Flammable Hazards – Pinch Points

**NOTE**

This section is for the High Pressure Gas Cylinders that are equipped with protective caps by the manufacturers. For example, the argon cylinders, acetylene cylinders, etc. The one exception is for ISFSI Dry Runs and Fuel Loading Campaigns. Inert gas cylinders, provided by the vendor, will be allowed to arrive on site and stored in bolted cradles without caps.

**NOTE**

SCBA's, CO2 Fire Extinguishers, Freon Containers, and other similar containers are not specifically addressed by this section. However, the guidelines in this section should be followed whenever possible.

**Key Point**

Compressed gas cylinders can be charged to from 2000 to 4000 psi. If the valve is damaged, they can become missiles that can go through concrete walls.

**Key Definitions**

1. **In Use** - Compressed gas cylinders are considered to be “in use” whenever gas is flowing from the cylinder to the intended application, or the cylinder is attached to an active manifold or supply line.
  - a. If cylinders are connected for use as in the case of oxygen and acetylene cylinders attached to regulators and staged in a welding/cutting torch arrangement or
  - b. If the oxygen and acetylene are capped and in a welding/cutting torch cart, they are considered to be “in use” only if they are planned to be used in the next 24 hours.
2. **In Storage** – Compressed gas cylinders are considered to be “in storage” when they have cylinder caps on them and are not being actively transported.
3. **In Transport** - Compressed gas cylinders are considered to be “in transport” when they are being transported from being “in use” to being “in storage” and vice-versa.

**General Safe Work Practices**

1. Compressed gas cylinders, whether full or empty, whether in storage, use, or in transport, shall be secured such that they cannot fall or be upset. Acceptable methods of restraint include permanent racks, restraint devices, carts designed for free standing use or secured to acceptable structure with:
  - a. ¼ inch chain (minimum)
  - b. 1/8 inch aircraft cable (minimum)
  - c. ½ inch manila rope (minimum)
  - d. 3/8 inch nylon rope (minimum)
  - e. 1 inch strap (minimum)

2. Keep cylinder valves closed and capped at all times except when the cylinder is in use.
3. If a cylinder leaks and the leak cannot be stopped by simply tightening the valve or packing nut, move the cylinder outdoors to a well ventilated area.
4. If cylinders do not have fixed hand wheels, they shall have keys, handles, or non-adjustable wrenches on the valve stems while they are in use. In multiple cylinder installations, one key or handle is required for each manifold.
5. Wrenches shall not be used on valve hand wheels. If wheels are hard to open or close, or frozen, contact the supplier for instruction.
6. Close cylinder valves before moving them; when work is finished, and when it is empty.
7. Never use cylinders as rollers or supports whether they are full or empty.
8. Never attempt to mix gases in a cylinder.
9. Never tamper with a safety relief device or valve of a cylinder.
10. Keep cylinders far enough away from welding, cutting, and other spark producing operations so sparks and slag will not reach them or provide a fire resistant shield.
11. Do not place cylinders where they can become part of an electrical circuit. Keep them away from piping systems and other equipment that may be used for grounding electrical circuits.
12. Whenever they are in use, fuel gas cylinders shall be placed with the valve end up.
13. Do not take compressed gas cylinders, other than air, into confined spaces.
14. When working with air and gas regulators:
  - a. Make sure the regulator is rated for the pressure to be used.
  - b. Make sure the fittings are rated for the pressure to be used.
  - c. Make sure the gauges are appropriate for the pressure to be used.
  - d. Relieve all pressure on regulator seats when not in use.
15. When placing compressed gases in service, if regulator pressure setting is unknown, adjust the regulator to minimum pressure and open cylinder valve slowly.
16. The number of oxygen/acetylene welding/cutting torches connected for use should be kept to a minimum. If oxygen/acetylene cylinders are not to be used in the next 24 hours, they must be stored properly by separating at a distance of 20 feet or by providing a ½ hour rated partition that is at least 5 feet high between cylinders.
17. Never use oils or greases in oxygen systems. This could produce a fire or explosion hazard.
18. If acetylene cylinders are transported or stored on their side, stand upright and allow at least one hour prior to use. This applies to all sizes of acetylene cylinders.
19. Only tools designed for protective cap removal should be used for cap removal.
20. Cylinders stored outside shall be secured to a fixed object or secured to a cart and placed on a flat/level surface.

### **Transporting and Moving Cylinders**

1. Do not hoist cylinders without using a cylinder truck, pallet, or similar device. The intent is to rig to the device holding the cylinder and not to the cylinder itself.
2. Do not use valve protection caps for lifting cylinders.
3. When moving cylinders short distances, tilting and rolling them on their bottom edges is acceptable. If it is a cylinder that can be hand carried, use extreme care when carrying.
4. When moving cylinders long distances or up and down stairs or ramps, a hand truck, fork truck or similar device should be used.
5. When transporting cylinders by powered vehicles, they must be secured and capped.
6. Regulators shall be removed and caps replaced when moving cylinders unless the cylinder is firmly secured on a special carrier (e.g. welding cart, etc.) intended for that purpose.

### **Storage**

1. Oxygen cylinders shall be separated from fuel gas cylinders or combustible materials a minimum of 20 feet, or by a non-combustible barrier at least five feet high having a fire resistant rating of at least one half hour.
2. Mark or tag cylinders to indicate which bottles are full, in-use or empty. Close valves on empty cylinders.
3. Normally store cylinders inside of buildings in well protected, well ventilated, dry locations. If cylinders are stored in the open, they shall be protected from the ground beneath to prevent rusting.
4. Do not store oxygen and fuel gas cylinders in unventilated enclosures such as lockers unless they are specifically designed for that purpose.
5. Post the names of the stored cylinders in cylinder storage areas. Store cylinders grouped by types of gases taking into account the hazards of the gases.
6. Do not expose cylinders to continuous dampness or store near salt or other corrosive chemicals or fumes.

### **Liquid Nitrogen Handling (Cryogenics)**

1. Dewars should not be laid on their side.
2. Personnel are not to ride on elevators while transporting Dewars.
3. When handling nitrogen or other cryogenics outside of a closed system, follow the PPE requirements listed in the PPE section of the SWPM.
4. If handling nitrogen, contact Chemistry to determine if an Atmospheric Hazard Permit is required. See Atmospheric Hazard section of SWPM.
5. Dewars are not subject to the restraint requirements when in use and storage.

### **References:**

Compressed Gas Cylinder Association, P 1 Pamphlet, Safe Handling Rules for Compressed Gas Cylinders  
29CFR1910.252, Welding, Cutting, and Brazing

**CONCRETE CORE DRILLING/CONCRETE CUTTING**

Intent	Prevent injuries to personnel and or damage to plant systems embedded in concrete.
Applicability	Applies to concrete drilling, cutting or coring into concrete structures.
Hazards	Electrical Shock – Electrocutation – Cuts – Eye Injury

**Key Point**  
Only drill or cut into concrete in accordance with EDP-ZZ-04050 and ES-REG-215.

**General Safe Work Practices**

1. Refer to EDP-ZZ-04050 for specific requirements concrete core drilling and/or cutting.
2. Follow the PPE requirements listed in the PPE section of the SWPM and the PPE section of the Electrical Safe Work Practices Manual (ESWPM).
3. Ensure electric drills and tools are connected to a power source through a working Ground Fault Circuit Interrupter (GFCI).

**CAUTION**

The GFCI does NOT take the place of, nor act like a drill stop. The GFCI provides protection from electrical faults in the power tool only. It will not provide protection from electrical shock from external sources.

4. Ensure electronic drill stop is attached to the drill and is operational.
5. If cutting/drilling into concrete using means other than an electric drill or tools capable of being connected to an electronic drill stop (i.e. cut-off saw, etc.) authorization must be documented on Post Pour Installation Form (PPIF) in accordance with EDP-ZZ-04050.
6. Drill stops can be disconnected only when authorized on PPIF in accordance with EDP-ZZ-04050.

**NOTE**

An electronic drill stop is designed to interrupt the electrical power supply to the drill as soon as the drill bit comes in contact with any metallic object that might be embedded in the concrete such as rebar or electrical conduit.

7. Ensure all electrical circuits near the drilling operation that might be contacted by the cooling water of core drilling operation are tagged out or otherwise protected from the water.
8. Install rebar caps on the ends of exposed rebar to prevent the risk of impalement.

**References:**

EDP-ZZ-04050, Civil/Structural Activities  
ES-REG-215

**CONFINED SPACES**

Intent	Provide general guidance concerning Confined Space Control.
Applicability	Applies to all work activities that involve confined spaces.
Hazards	Hazardous Atmospheres – Difficult Rescue Situations – Flammable Atmospheres

**Key Point**

Most people who die in confined space accidents are would-be rescuers who instead become victims.

**A confined space is a space that:**

1. Is large enough and so configured that a person can bodily enter and perform work, and
2. Has limited or restricted means for entry or exit (for example tanks, vessels, vaults, heaters, and pits are spaces that may have limited entry), and
3. Is not designed for continuous employee occupancy.

**A Permit Required Confined Space is a confined space that:**

1. Has additional hazards associated with it such as an atmospheric hazard, downward sloping walls that could cause you to fall and become trapped, or other physical hazards such as exposed electrical conductors or fall hazards.
2. For Permit Required Confined Spaces a briefing will be conducted, and the work will be carefully planned prior to any entry.

**General Safe Work Practices**

1. Entry into a confined space is governed by APA-ZZ-00802.
2. Safety and Chemistry personnel will assist you if any questions arise.
3. Follow the PPE requirements listed in the PPE matrix of the SWPM.
4. If rescue planning is necessary, see “Medical Emergency Response Team (MERT) and Fire Brigade” section of the SWPM for more information.

**References:**

APA-ZZ-00802, Confined Space Program  
29CFR1910.146, Permit Required Confined Spaces

**CRANES LIFTING AND RIGGING**

Intent	Provide information to reduce the probability of injuries or accidents associated with hoisting and lifting operations.
Applicability	Hoisting and Lifting Operations
Hazards	Trauma – Electric Shock – Falling Objects – Pinch Points – Puncture

**Key Point**  
Any time we rig and lift, we have the potential to seriously injure or kill someone.

**General Requirements**

1. Refer to APA-ZZ-00365, Callaway Energy Center Lifting and Rigging Program for specific rigging instructions.
2. Follow the PPE requirements listed in the PPE section of the SWPM.

**References:**

APA-ZZ-00365, Callaway Energy Center Lifting and Rigging Program

**DIVING OPERATIONS**

Intent	Reduce the potential for injuries associated with diving operations.
Applicability	Applies to diving work activities.
Hazards	Drowning – Confined Spaces

**Key Point**

Diving operations are special work activities presenting unique hazards and special safety practices.

**General Safe Work Practices**

1. If performing diving operations in a radiological controlled area, use HTP-ZZ-06019 to perform diving operations.
2. If diving in a non-radiological area, use MDP-ZZ-D0001 to perform diving operations.
3. Designate an Ameren Missouri Project Coordinator.
4. Evaluate the dive to ensure the diver will not be entering a confined space. If there is a potential to enter a Confined Space, contact Chemistry or Safety for an evaluation per APA-ZZ-00802. Diving in a confined space is a Permit Required Confined Space due to the hazardous atmosphere.
5. Ensure WPA is in accordance with APA-ZZ-00310.
6. Ensure all fall protection criteria have been met.

**NOTE**

The “Consensus Standards for Commercial Diving and Underwater Operations” published by the Association of Diving Contractors is recognized as meeting the general requirements of a safe practices manual.

7. Ensure dive vendor has a Safe Practices Manual containing procedures and checklists for diving operations, assignments and responsibilities of dive team members, equipment procedures and checklists, and emergency procedures (at a minimum: fire, equipment malfunction or failure, adverse environmental conditions, and medical injury/illness). The safe practices manual guidance and procedures must be supplemented with additional information specific to each diving operation. This information must be communicated to the dive team during the pre-job brief.

**References:**

- 29CFR1210. Subpart T Commercial Diving Operations
- HTP-ZZ-06019, Diving Operations
- MDP-ZZ-D0001, Non RCA Diving Operations
- APA-ZZ-00310, Workman’s Protection Assurance
- 29CFR1910.421 Pre-Dive Procedures

**ELECTRIC EXTENSION CORDS/FLEXIBLE CORDS, CABLES, AND OUTLETS**

Intent	Reduce the potential for injuries associated with the use Extension Cords/Flexible cords.
Applicability	Applies to all work activities that involve the use of any flexible cords.
Hazards	Electrical Contact – Electrical Flash – Slips/Trips

**Key Point**

Great care must be taken to ensure insulation on electric cords is not damaged and that their routing does not create a tripping hazard.

**General Safe Work Practices**

1. Extension cords, power strips, GFCI's and light stringers should all be inspected prior to use. If visible damage is present, remove from service and do not use until inspected by an electrician. If the cord will not be inspected immediately, tag with a "DANGER Do Not Use" tag.
2. Electrical tape shall not be used to repair damage to flexible power cords. If the outer cord jacket is damaged, Danger Tag the cord and give it to the Maintenance Electrical shop for disposal.
3. Extension cords may not be routed through walls or ceilings such that they cannot be inspected prior to each use.
4. Place cords so they are not damaged by doors, sharp corners, pinch points, etc. Use cable shields or other suitable protection.
5. If the cord can be placed under the door in a manner that it will not be damaged (i.e. there is an adequate gap under the door), the cord must be taped or otherwise secured so the cord cannot move and be damaged by the door. Fire doors will be considered impaired and require an FPIP.

**NOTE**

The Control Room Supervisor must be contacted prior to propping open a Fire or Security door.

6. If the cord has to be routed through the door and it cannot be adequately protected, block the door open. The door will be considered impaired and require an FPIP.

**Extension Cords**

1. Use heavy duty extension cords in the power block and all areas other than office areas. All extension cords must be UL listed or equivalent.
2. Route cords in a manner to minimize their becoming a tripping hazard and minimize the potential for the cord to be damaged. Normally, route cords at least seven feet overhead, or under grating, or along the edges of the walls.
3. An attempt **MUST** be made to obtain an extension cord of the proper length for the job. Extension cords can be plugged together in a tandem arrangement provided they are rated for the expected loads in that configuration.
4. You must use a Ground Fault Circuit Interrupter (GFCI) when using electric hand tools such as drills, grinders, heat guns, etc. plugged into an electrical outlet of 15 or 20 amps. Any electrical device or extension cord plugged into a permanent outlet outside or in a potential water environment requires the use of a GFCI. The use of a GFCI does not remove the requirement to inspect the extension cord and electrical hand tool prior to use. Multiple GFCI's should not be used in the same run.

5. If the GFCI device is separate from the extension cord it **MUST** be plugged into the outlet upstream of the extension cord. If more than one cord is used the GFCI must be upstream of **ALL** extension cords.
6. GFCI adapters used with extension cords and permanently installed receptacles must have their GFCI protection circuits tested before each use. Testing of the GFCI device must be per the manufacturer's instructions.
7. Do not alter plugs or receptacles.
8. Do not alter or remove ground poles.
9. Place light stringers overhead at least seven feet or ensure they have lamp guards.
10. Temporary lighting has no restriction on the length of time that it is in service.
11. Temporary power cords and extension cords can only be used for 90 days unless the following conditions exist: periods of construction; remodeling; maintenance; repair or demolition of buildings, structures and equipment; or similar activities. ENSURE requirement of MDP-ZZ-0STOR are met.
12. Permanent plant equipment or electrical devices that do not fall into the exempt categories in Section 11 above and are in place for longer than 90 days are required to have a permanent power supply consisting of fixed wiring of a structure. Use of temporary power cords and extension cord to power this equipment is acceptable as long as a Condition Report (CR) has been written to install permanent power during the normal course of business. The CR for this job should state that there is a safety concern. An "In Process" Tag with the date, owner's name, expected duration, and CR number must be on the cord.
13. Temporary power cords installed longer than 90 days should be inspected on semi-annual basis.

#### **480-Volt Receptacles**

1. Do not plug into or unplug from a 480-volt receptacle that is energized.
2. If you need to utilize a 480-volt receptacle that does not have a local disconnect, contact Operations to de-energize the receptacle prior to unplugging. A de-energized state must be verified prior to plugging in or unplugging. Once the action is complete, contact Operations to re-energize the receptacle.
3. Voltage testing is not required when the receptacle is equipped with a local disconnect.

#### **Power Strips**

1. They are to be used to supply multiple low amperage loads. Ensure that the total load does not exceed the manufacturer's rating.
2. Do not plug an extension cord into a power strip.
3. Power strips cannot be plugged into another power strip.

#### **Power Outlets (Permanent and Temporary)**

##### **NOTE**

The intent of this section is to prevent outlets from being overloaded by excessive current. The use of multiple larger appliances or electronic devices (3 or more) concurrently should be avoided. Contact your supervisor if you are unsure if a device is a higher amperage load.

1. Do not plug multiple appliances (3 or more) with higher amperage loads into the same outlet (ex: refrigerators, space heaters, and microwaves).

2. Inspect power cords and appliances before initial use and portable appliances periodically to ensure safe operation.

**References:**

29CFR1910.333, Selection and Use of Work Practices

CR 201007681

MDP-ZZ-0STOR

NEIL LCM

**ERGONOMIC WORKSTATION SET UP**

Intent	Provide guidance to properly set up office workstations.
Applicability	All employees working at office workstations
Hazards	Cumulative Trauma

**Key Point**  
Improper Workstation Set up can contribute to Cumulative Trauma Illnesses.

When setting up workstations, refer to APA-ZZ-00835 (refer to Ergonomic Workstation Set-up checklist).

**References:**

CA2506 Ergonomic Workstation Set-Up

**EXCAVATION SAFETY**

Intent	Provide general guidelines to prevent injuries associated with excavations.
Applicability	Applies to all work activities in excavations.
Hazards	Falls – Slips/Trips – Falling Objects – Atmospheric Hazards – Cave ins/Structural Failure

**Key Point**

Notify Engineering prior to any excavation operation.

**General Safe Work Practices**

1. Refer to MDP-ZZ-SH001 for specific instructions for work involving excavations.
2. Follow the PPE requirements listed in the PPE section of the SWPM.
3. OSHA Compliant Barriers should be installed 6 feet from trenches.

**References:**

29CFR1926, Subpart P, Excavations  
MDP-ZZ-SH001, Trenching and Shoring

**EYEWASH STATIONS/SHOWERS**

Intent	Provide adequate eye and body flushing in areas where the potential exists for splash or other contact of materials with the eyes and skin.
Applicability	Where the eyes or body of a person may be exposed to the injurious corrosive materials, suitable quick drenching or flushing of the eyes and body shall be provided within the work area for immediate use.
Hazards	Acids – Corrosives – Irritants

**Key Point**

Immediate and adequate flushing of eyes and skin can minimize injury.

**General Safe Work Practices**

1. Ensure emergency showers and eyewashes or other suitable means for adequate drenching are present and working prior to performing work that exposes workers to hazardous materials.
2. For fixed, permanently installed eyewash stations/showers, check for operability by quickly flowing the eyewash/shower. Personnel testing the eyewash station/shower must clean up any water on the building floor. Reset alarms where applicable.
3. For portable eyewash stations/showers, do not flow the unit, but check to ensure it is charged.
4. Emergency showers and eyewash stations must:
  - a. Be free from obstruction.
  - b. Be located no more than 10 seconds from the hazard.
  - c. Be located where water spray will not contact electrical apparatus or outlets.
  - d. Be marked with identification.
  - e. Utilize potable water.
  - f. Be installed in a manner that ensures the water will not freeze or become excessively hot.
5. Eye wash bottles or portable spray units may be used at remote locations or where small quantities of hazardous materials are handled infrequently.
6. Self-contained portable eye wash station units may be used in areas remote from potable water supplies. The minimum size is a 10 gallon, 15 minute unit.

**When Emergency Shower and Eyewash Stations Are Removed From Service**

1. When Operations identifies potable water is to be isolated from an installed shower or eyewash, a note must be added to the WPA to notify the operations when potable water is isolated from an eyewash station/shower.
2. When the WPA is placed and the potable water is isolated, operations must place a sign in front of the affected eyewash station/shower. The signs should state **“CAUTION - Eyewash Stations/Showers Out of Service. Do Not Perform Chemical Handling Operations Unless a Temporary Eyewash/Shower is Present,”** or have similar wording. The sign SHOULD also include tracking number such as Job, WPA, RFR, etc. (CR 200000104)
3. When the WPA is removed and the potable water is restored, operations must remove the signs.
4. It is the responsibility of the work group exposed to the hazard to obtain a portable eyewash/shower prior to performing work.

**References:**

American National Standard for Emergency Eyewash and Shower Equipment  
CR 199903206  
CR 200000104

**FALL PROTECTION/ELEVATED AREAS**

Intent	Reduce the potential for injuries associated with work at heights.
Applicability	Applies to all work activities in elevated areas.
Hazards	Falls – Slips/Trips – Eye hazards

**Key Point**

Personnel on a surface within 6 feet of an unprotected side or edge, which is 4 feet or more above the lower level shall utilize, fall protection or restraint.

**Key Point**

When ascending/descending fixed, scaffold, or portable ladders where the climber reaches 20 feet or above, from the climbers' feet to the platform/level below, fall protection is required. Fall protection can consist of an installed cage, center ladder safety device, or retractable lanyard.

**CAUTION**

The use of bungee style lanyards at Callaway Energy Center is NOT permitted.

**Definitions:**

1. **Fall Protection** - a system used to arrest personnel in a fall from a working level. It consists of an anchorage, connectors, body harness and may include a lanyard, deceleration device, lifeline, or suitable combinations of these. Use only approved fall protection equipment.
2. **Restraint** - when a person is physically restrained removing the potential for a free fall. A Safety Belt may be used for restraint but must not be used for fall protection.
3. **Unprotected Side or Edge** – means any side or edge (except at entrances to points of access) of a walking/working surface, e.g. floor, roof, ramp, or runway where there is no wall of guardrail system at least 39 inches high.

## General Safe Work Practices:

### CAUTION

Additional fall protective measures will be utilized for areas within 6 feet of guard rails with a potential fall distance of greater than 4 feet to a lower level when work is taking place that could result in being struck or otherwise result in falling over or between rails of guard rail. Examples include arresting or restraining fall protection lanyards, netting, scaffold poles or similar placed between low, mid and upper hand rails.

1. Inspect all fall protection equipment prior to use and do not use it if deterioration or defects are noted. If a defect is identified, tag the equipment with a “DANGER Do Not Use” tag and return it to the tool room.
2. Verify weight limit on tag of fall protection equipment prior to use. Do not use if user weight is greater or less than the rating on the tag.
3. When using a body harness for fall protection, tie off to the D ring attachment point or manufacturer approved harness attachment point in the center of the back near shoulder level.
4. Harness, lanyards, and other fall protection components shall only be used for employee protection. Do not use them to lift equipment.
5. If fall protection equipment is subjected to impact loading, immediately remove it from service and tag the equipment with a “DANGER Do Not Use” tag. Return the equipment to the tool room as soon as practical.
6. If a fall occurs, notify Engineering and Safety so the anchor point that arrested the fall can be evaluated.
7. For acceptable tie off points, see the Approved Tie-Off Location chart in this section of the SWPM.

### NOTE

*Scaffold builders* may tie off to a horizontal scaffold member as Fall Protection Anchorage Point on *Excel Modular Scaffolding* only per Excel Tech Manual.

8. Scaffold tie-off points for fall protection are on a vertical post at joint with a horizontal member.
9. When practical, the anchorage point for fall protection equipment must be located at or above the harness D ring or manufacturer approved harness attachment point.
10. When the anchorage point is below the D ring or manufacturer approved harness attachment point:
  - a. Ensure you select the appropriate lanyard for the task.
  - b. Your anchorage point must be in a location that will prevent you from striking the lower level.
  - c. In all circumstances, the anchorage point must be located in a position that will minimize the potential fall distance.
  - d. Follow the manufacturers guidance for attachments below the D ring.

11. Fall protection anchorage points should be used in a manner to minimize the potential for swing falls and pendulum effect injuries. The greater the angle from directly overhead the greater the potential for pendulum effect injuries.
12. Consult the tie off location chart for the Self-Retracting Lifeline (SRL) you will be using.

**NOTE**

The fall protection anchorage should always be as close to overhead as possible to limit the freefall distance. When an anchorage that provides adequate clearance is not available, other alternatives such as scaffold, ladders, or manlifts must be considered.

13. Lanyards shall not be hooked back onto themselves unless they are specifically designed for that purpose.
14. Horizontal lifelines must be designed and installed under the direction of Engineering.
15. When working over water, utilize fall protection, restraint, or life vest unless the distance to the water is greater than or equal to 10 feet, then fall protection or restraint is required.
16. The use of a safety belt attached to a ladder safety device is acceptable for climbing, descending, or working. Do not use a lanyard with an installed ladder safety device.
17. When ascending/descending fixed, scaffold, or portable ladders where the climber reaches 20 feet or above, fall protection is required. Fall protection can consist of an installed cage, center ladder safety devices, or retractable lanyard.
18. When working from any ladder fall protection is required when working:
  - a. Torso or trunk is outside the rails of the ladder
  - b. Above handrails
  - c. Leaning back on ladder
19. Use the choker method when using approved straps for an anchorage point.

**NOTE**

For guidance concerning climbing on plant equipment, refer to the section of this manual titled, "Standing or Stepping on Plant Equipment."

**Openings in Walking and Working Surfaces** (*This does not include excavations. For excavations, see excavation section of this manual*).

Every temporary floor opening shall have standard railings or shall be constantly attended by someone. If the opening has a fall of 4 feet or greater, utilize the following:

1. While attended, if barricades are not already in place, install red barricade tape no less than 6 feet from the floor opening with a Danger Sign stating, "Open Hole, fall protection required beyond this point". If Danger tape must be temporarily taken down for equipment removal, spotters shall be used to prevent personnel entry into that area without proper fall protection.

2. If personnel are within 6 feet from the edge of a floor opening presenting a fall hazard of 4 feet or greater, the use of fall protection or restraint is required.
3. When unattended, the floor opening must be covered with a temporary cover, or temporary handrails.
4. Temporary handrails must be approximately 42 inches high with a mid-rail installed.
5. A Danger Sign stating "Open Hole, fall protection required beyond this point" must be installed on swing gates of temporary barricades constructed to block access to an area where an open hole has been created with a fall hazard 4' or greater. This does not apply to permanently installed swing gates or railings, temporary handrails where access is not provided, or temporary barriers that are covered under other programs such as confined space (ie: man hole entries) where a Danger Sign is required.

### **Temporary Covers**

Temporary covers for holes in floors, roofs, and other walking/working surfaces shall meet the following requirements:

1. If located in roadways or vehicle aisles, they shall be capable of supporting at least twice the maximum axle load of the largest vehicle expected to cross over the cover.
2. All other covers shall be capable of supporting at least twice the weight of employees, equipment, and materials that may be imposed on the cover at any one time.
3. All covers shall be secured when installed so as to prevent accidental displacement by the wind, equipment, or employees.
4. All temporary covers for holes in floors, roofs, and other walking/working surfaces must be marked as follows "Hole Cover – Do Not Remove".

### **Use of Crane Hook for a Tie Off Point**

1. ONLY use Overhead Crane Hooks as tie off points for fall protection IF directed by an approved Callaway procedure OR approved by Callaway Crane Engineer AND Safety Supervisor, or their designees.
2. ONLY use Mobile Crane Hooks for a tie-off point for fall protection IF all of the following precautions are observed:
  - a. ENSURE crane outriggers are fully extended and pinned (IF designed for)
  - b. ENSURE mobile crane is level (less than one (1) degree variance)
  - c. ENSURE engine is turned off when personnel are attached to the tie off point
  - d. IF equipped, ENSURE swing brake or cab lock is set
  - e. ENSURE crane is set for a capacity of at least 5000 lbs. per person who will be tied off (This requirement can be reduced by a Master Rigger review)
  - f. ENSURE each person is independently attached to the load block or overhaul ball
  - g. CONSIDER using a retractable lanyard or rope grab to minimize the need to move tie-off point
  - h. ENSURE crane operator stays at the immediate job site when a mobile crane is used for personnel tie off and items 2.a thru 2.f above are met.

**Use of powered equipment (e.g. backhoes, trackhoes, loaders, etc.) as tie-off points:**

Powered equipment can be utilized as a means for fall protection restraint or arrest provided the following conditions are met:

1. No other tie-off options exist (items such as Jersey Barriers, large concrete weights or similar devices can often provide better anchorage points)
2. The equipment that is being used as an anchor point can provide a 5,000lb anchor point per person tied off
3. An adequate rigging point for the fall protection equipment is available.
4. The equipment is turned off with the keys removed

**Exceptions to Fall Protection:**

When approved by the Safety Department for specific instances such as excavations and work on roofs, workers may proceed directly to/from the ladder access without being attached to a fall protection device providing the act of attaching/detaching from fall protection will increase the risk of a fall. This does not apply when the ladder travel distance is 20' or greater. CEC Safety will approve this access variance on a case-by-case basis.

Rolling stock, (*trailers, mobile cranes, etc.*) are excluded from fall protection requirements. IF equipment on a trailer is climbed on, and over 4', THEN fall protection IS required.

Vehicle Barrier System (VBS) blocks are 42" to 46" high and DO NOT require the use of fall protection when standing on. The exception to this are the three blocks outside the PA at Oily Waste that are double stacked to a height of 62" and WILL require the use of fall protection when working on top of them.

**First Man Up Tool** – This is located in the tool room and is available for installing anchor points.

**Fall Protection Chart** -The following chart list the applicable fall protection tie-off points that have been approved (Reference RFR 16862A).

**Approved Tie-Off Location Chart**

All units are in Feet	DBI Sala Class 2 1,800 # X 2		DBI Sala Class A/B or Class 1 1,350 X 2		Plant Installed Retractable 712 X 2	
	Cantilever	Simple Span	Cantilever	Simple Span	Cantilever	Simple Span
Fixed Permanent Ladders: rungs or beams						
1- 1/4" Handrail Pipe ASTM A53:						
Horizontal Top or Midrail	N/A	NO GOOD	N/A	NO GOOD	N/A	NO GOOD
Vertical Post	Base Only	N/A	Base Only	N/A	Base Only	N/A
Tube Steel 3X3X1/4"	2.5	11.0	3.5	15.0	7.0	Any L
Tube Steel 4X4X1/4"	5.0	21.0	7.0	Any L	13.5	Any L
Tube Steel 6X6X1/4"	13.0	Any L	17.5	Any L	Any L	Any L
W 4X13	7.0	Any L	9.5	Any L	18.0	Any L
W 6X15	13.0	Any L	17.5	Any L	Any L	Any L
W 6X20	17.5	Any L	Any L	Any L	Any L	Any L
2" Conduit*	N/A	3.0	N/A	4.0	N/A	7.5
2 1/2" Conduit*	N/A	5.5	N/A	7.5	N/A	14.5
3" Conduit*	N/A	9.5	N/A	12.5	N/A	20'
3 1/2" Conduit*	N/A	13.0	N/A	17.5	N/A	20'
4" Conduit*	N/A	17.5	N/A	20'	N/A	20'
1.9" Std. Scaffold Pole	NO GOOD	1.0	NO GOOD	1.5	NO GOOD	2.5

All units are in Feet	DBI Sala Class 2 1,800 # X 2		DBI Sala Class A/B or Class 1 1,350 X 2		Plant Installed Retractable 712 X 2	
	Cantilever	Simple Span	Cantilever	Simple Span	Cantilever	Simple Span
Pipe, 2", A106 Grade B, Sch 40	<b>NO GOOD</b>	3.0	1.0	4.0	1.5	7.5
80	1.0	4.0	1.0	5.0	2.5	10.0
160	1.0	5.0	1.5	7.0	3.0	13.5
Pipe, 3", Sch 40	2.0	9.5	3.0	12.5	6.0	Any L
80	3.0	12.0	4.0	16.0	7.5	Any L
160	3.5	15.5	5.0	Any L	10.0	Any L
Pipe, 4", Sch 40	4.0	17.5	5.5	Any L	11.0	Any L
80	5.5	Any L	7.5	Any L	14.5	Any L
160	8.0	Any L	10.5	Any L	20.5	Any L
Pipe, 6", Sch 40	11.5	Any L	15.5	Any L	Any L	Any L
80	16.5	Any L	Any L	Any L	Any L	Any L
160	Any L	Any L	Any L	Any L	Any L	Any L
Pipe, 2", Type 304 SS, Sch 40	<b>NO GOOD</b>	3.5	1.0	4.5	2.0	9.0
80	1.0	4.5	1.5	6.0	2.5	11.5
160	1.5	6.0	2.0	8.0	4.0	16.0
Pipe, 3", Sch 40	2.5	11.0	3.5	14.5	7.0	Any L
80	3.5	14.0	4.5	19.0	9.0	Any L
160	4.5	18.5	6.0	Any L	11.5	Any L
Pipe, 4", Sch 40	5.0	20.5	6.5	Any L	13.0	Any L
80	6.5	Any L	9.0	Any L	17.0	Any L
160	9.5	Any L	12.5	Any L	Any L	Any L
Pipe, 6", Sch 40	13.5	Any L	18.0	Any L	Any L	Any L
80	19.5	Any L	Any L	Any L	Any L	Any L
160	Any L	Any L	Any L	Any L	Any L	Any L
4" High Cable Tray Side Rail	N/A	3.5	N/A	5.0	N/A	9.5
1½" Shebolt	<b>NO GOOD</b>	N/A	<b>NO GOOD</b>	N/A	0.5	N/A
Grating Std. Tie Off at Support	Tie-off at grating support (beams) Support from 3 bearing bars minimum					
Grating Std. Tie Off at Midspan (5' span or less)	Tie-off at grating midspan: Support from 19 bars for ANSI/ASSE Z359 (1,800 Lbs. X 2), 15 bars for nano-lok, 8 bars for retractable (yo-yos).					
Expansion Anchors	1" ONLY with 6" Embedment- Must have enough thread projection to mount tie-off eye and hex nut					
Unistrut P1000	<b>NO GOOD</b>	<b>NO GOOD</b>	<b>NO GOOD</b>	<b>NO GOOD</b>	<b>NO GOOD</b>	2.0
P1001	<b>NO GOOD</b>	2.5	<b>NO GOOD</b>	3.5	1.5	6.5
P5000	<b>NO GOOD</b>	3.0	<b>NO GOOD</b>	4.0	1.5	7.5
P5001	2.0	9.0	3.0	12.0	5.5	Any L

\*Note: Conduit is the same as standard pipe. Conduit must bear directly on support steel.

### Items Not Allowed For Tie-Off:

1. Handrail Top and mid rails • Structural tubing < 3inches • conduit < 2 inches • Tubing & tube support
2. Expansion anchors • Snubbers • Pipe Struts • Pipe Spring Cams • Valve actuators • HVAC ducts < 18 inches in height
3. Fire Protection Piping • Lube Oil Piping • Flammable Gas Piping • Floor Drain Piping • Process auxiliary piping for safety related areas • Instruments • Hoses

## Restraints

### NOTE

Restraints are an engineering control designed to prevent worker from accessing fall hazard.

- Will be used on Aerial work platforms (JLG's) until minimum height, per fall clearance chart, has been established.
- Restraints should be adjusted to correct the length to protect worker from fall hazard.
- When areas cannot be made "fall protection not required" and fall clearances cannot be maintained per specific clearance charts, a restraint should be used.
- Restraints shall be inspected prior to use, using the same criteria as fall protection.

## Class A/B Self-Retracting Lifeline

Self-Retracting Lifelines (SRL) are the primary harnesses approved for use at Callaway Energy Center. Ensure the Correct SRL is selected for the application.

### Class A/B Self-Retracting Lifeline

- Not for use in leading edge applications
- Tie off permitted up to 36" below the D-ring (users up to 310lbs)
- Tie off permitted up to 24" below D-ring for users between 310lbs and 420lbs.
- Add an additional 1' of required clearance for users over 310lbs.
- When anchored within 3 feet of directly overhead minimum fall clearance is 4' for a user up to 310lbs.
- Minimum weight 130 lbs.

### Class A/B Nano-Lok

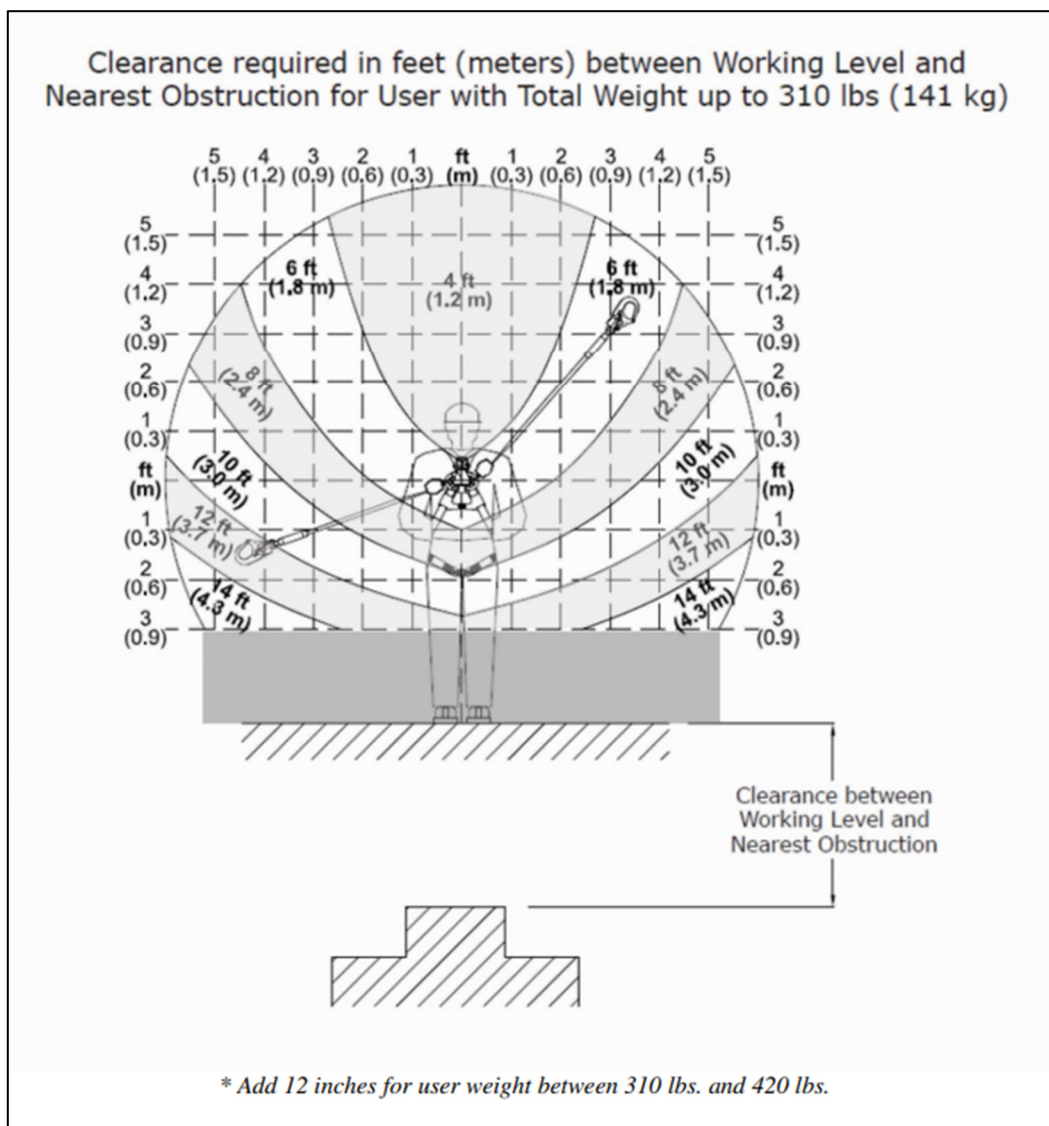

### Class 1 Self-Retracting Lifeline

- Must be attached to anchorage at the D-ring or above.
- Minimum weight 130 lbs.

Never secure your connector within chart areas marked by cross hatching or crossed-out table cells.

### Fall Clearance Chart #1

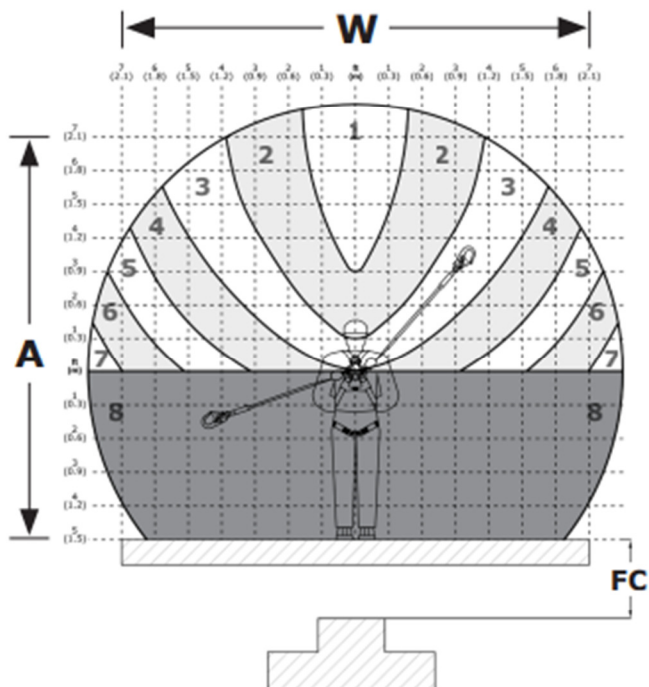

Weight	Chart Area							
	1	2	3	4	5	6	7	8
130 lb. - 220 lb. (59 kg - 100 kg)	4.8 ft. (1.5 m)	6.0 ft. (1.8 m)	7.0 ft. (2.1 m)	8.5 ft. (2.6 m)	9.5 ft. (2.9 m)	11.5 ft. (3.5 m)	13.0 ft. (4.0 m)	Do not connect in this area.
<b>Fall Clearance (FC)</b>								

Key
A = Anchorage Height
W = Maximum Work Radius
FC = Required Fall Clearance

**Class 1 Self-Retracting Lifeline**

**Fall Clearance Chart #2**

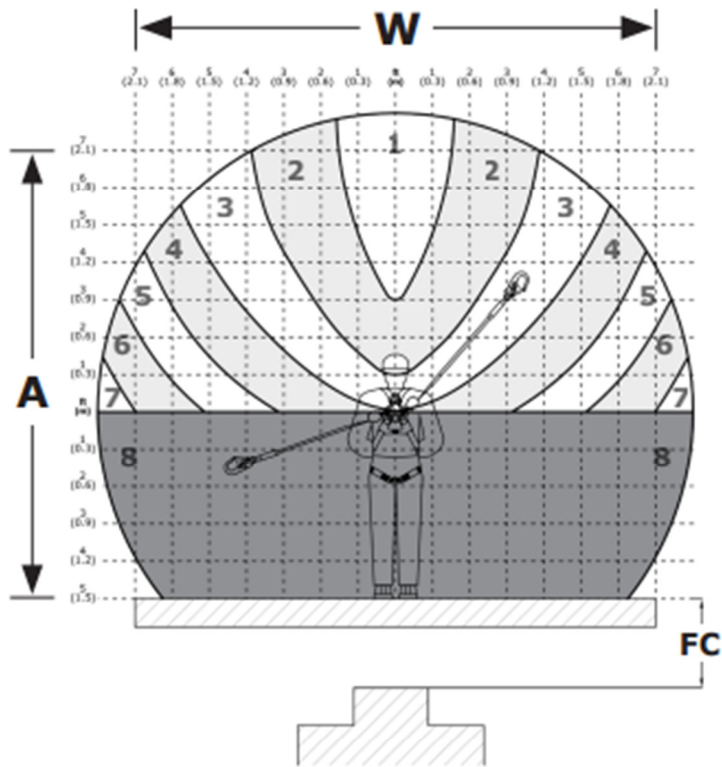

Weight	Chart Area							
	1	2	3	4	5	6	7	8
221 lb. - 310 lb. (101 kg - 140 kg)	5.0 ft. (1.5 m)	7.0 ft. (2.1 m)	8.0 ft. (2.4 m)	9.0 ft. (2.7 m)	10.0 ft. (3.0 m)	12.0 ft. (3.7 m)	13.0 ft. (4.0 m)	Do not connect in this area.
<b>Fall Clearance (FC)</b>								

Key
A = Anchorage Height
W = Maximum Work Radius
FC = Required Fall Clearance

**Class 1 Self-Retracting Lifeline**

**Fall Clearance Chart #3**

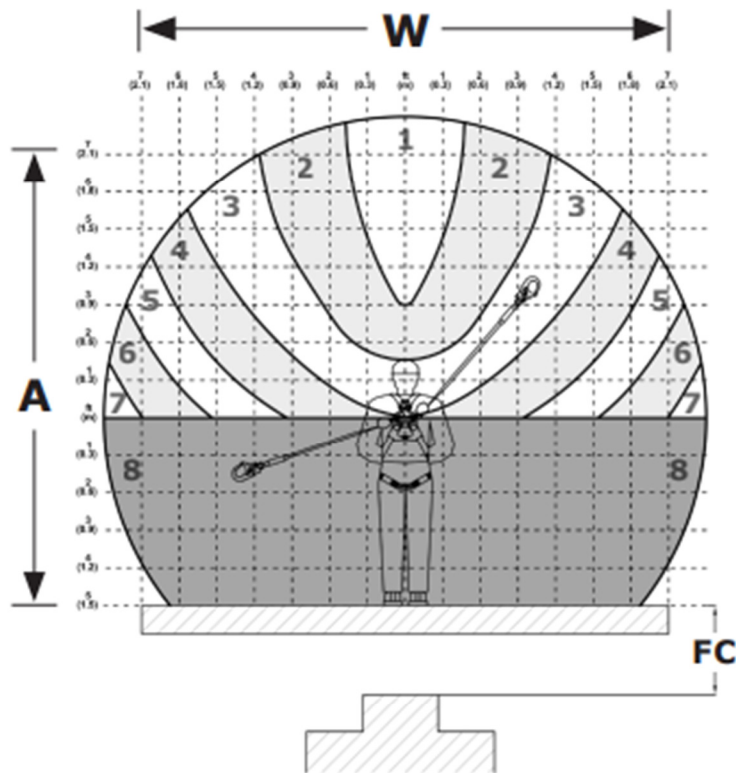

**Weight**

**Chart Area**

Weight	Chart Area							
	1	2	3	4	5	6	7	8
311 lb. - 420 lb. (141 kg - 191 kg)	6.7 ft. (2.0 m)	8.5 ft. (2.6 m)	11.0 ft. (3.4 m)	13.5 ft. (4.1 m)	15.0 ft. (4.6 m)	18.5 ft. (5.6 m)	20.0 ft. (6.1 m)	Do not connect in this area.

**Fall Clearance (FC)**

**Key**

- A = Anchorage Height
- W = Maximum Work Radius
- FC = Required Fall Clearance

### Class 2 Self-Retracting Lifeline

- Provides leading edge protection
- Anchorage to foot level (Up to a 310lbs user)
- Users 311-420lbs can only tie off 24" below the D-ring.
- Minimum weight 130 lbs.

Never secure your connector within chart areas marked by cross hatching or crossed-out table cells.

### Fall Clearance Chart #1: 130 lb. - 220 lb. (59 kg - 100 kg)

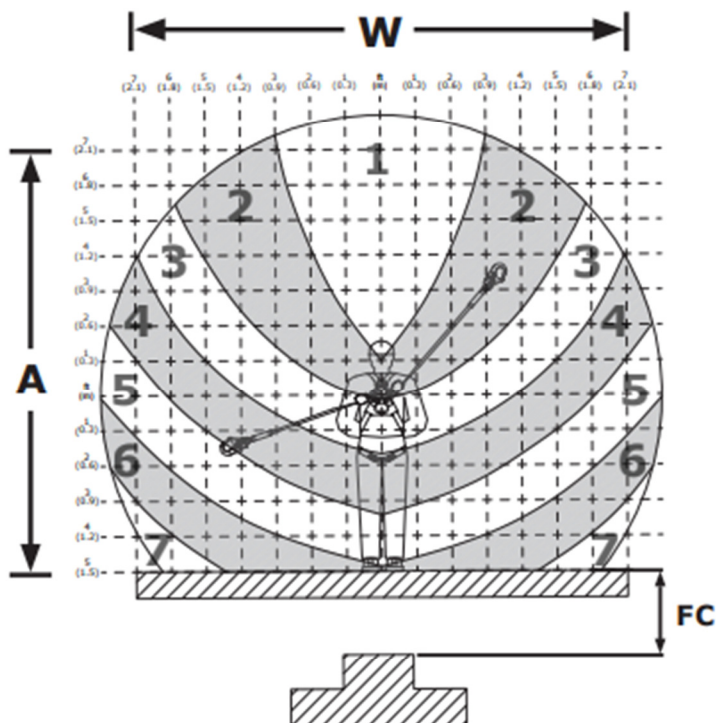

		Chart Area						
		1	2	3	4	5	6	7
Single-SRD Models		6.0 ft. (1.8 m)	8.0 ft. (2.4 m)	10.0 ft. (3.0 m)	12.0 ft. (3.7 m)	14.0 ft. (4.3 m)	16.0 ft. (4.9 m)	18.0 ft. (5.5 m)
Twin-SRD Models		6.0 ft. (1.8 m)	8.0 ft. (2.4 m)	10.0 ft. (3.0 m)	12.0 ft. (3.7 m)	14.0 ft. (4.3 m)	16.0 ft. (4.9 m)	18.0 ft. (5.5 m)
		Fall Clearance (FC)						

Key	
A	= Anchorage Height
W	= Maximum Work Radius
FC	= Required Fall Clearance

**Class 2 Self-Retracting Lifeline**

**Fall Clearance Chart #2: 221 lb. - 310 lb. (101 kg - 140 kg)**

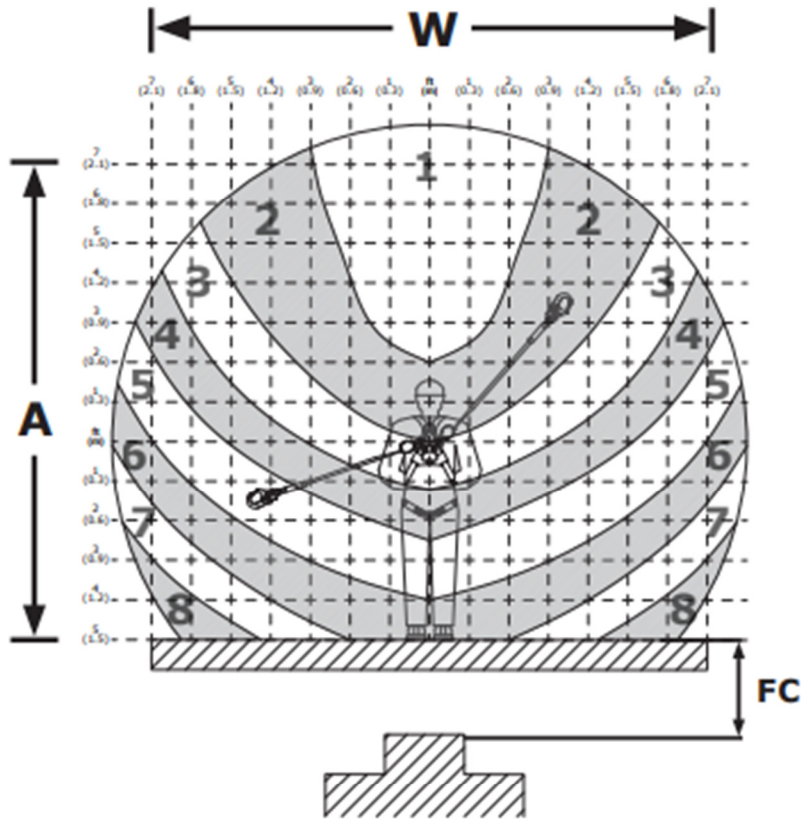

Chart Area								
	1	2	3	4	5	6	7	8
Single-SRD Models	7.0 ft. (2.1 m)	9.0 ft. (2.7 m)	11.0 ft. (3.4 m)	13.0 ft. (4.0 m)	15.0 ft. (4.6 m)	17.0 ft. (5.2 m)	19.0 ft. (5.8 m)	21.0 ft. (6.4 m)
Twin-SRD Models	7.0 ft. (2.1 m)	8.0 ft. (2.4 m)	10.0 ft. (3.0 m)	12.0 ft. (3.7 m)	14.0 ft. (4.3 m)	16.0 ft. (4.9 m)	18.0 ft. (5.5 m)	20.0 ft. (6.1 m)
Fall Clearance (FC)								

Key
A = Anchorage Height
W = Maximum Work Radius
FC = Required Fall Clearance

Class 2 Self-Retracting Lifeline

**Fall Clearance Chart #3: 311 lb. - 420 lb. (141 kg - 191 kg)**

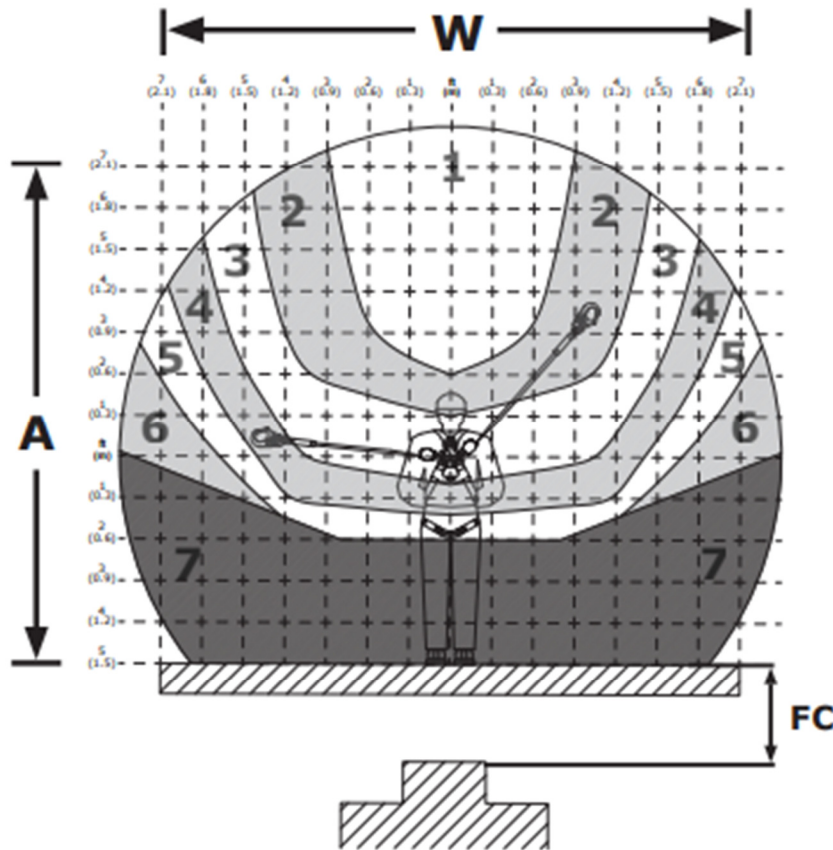

Chart Area							
	1	2	3	4	5	6	7
Single-SRD Models	9.0 ft. (2.7 m)	11.0 ft. (3.4 m)	13.0 ft. (4.0 m)	15.0 ft. (4.6 m)	17.0 ft. (5.2 m)	19.0 ft. (5.8 m)	Do not connect in this area.
Twin-SRD Models	9.0 ft. (2.7 m)	10.0 ft. (3.0 m)	12.0 ft. (3.7 m)	14.0 ft. (4.3 m)	16.0 ft. (4.9 m)	18.0 ft. (5.5 m)	Do not connect in this area.
<b>Fall Clearance (FC)</b>							

Key
A = Anchorage Height
W = Maximum Work Radius
FC = Required Fall Clearance

### Aerial Work Platforms (AWP)

- The following Charts are for use with Class 2 SRLs, each chart corresponds with the weight of the user.

Never secure your connector within chart areas marked by cross hatching or crossed-out table cells.

**Fall Clearance Chart #1: 130 lb. - 220 lb. (59 kg - 100 kg)**

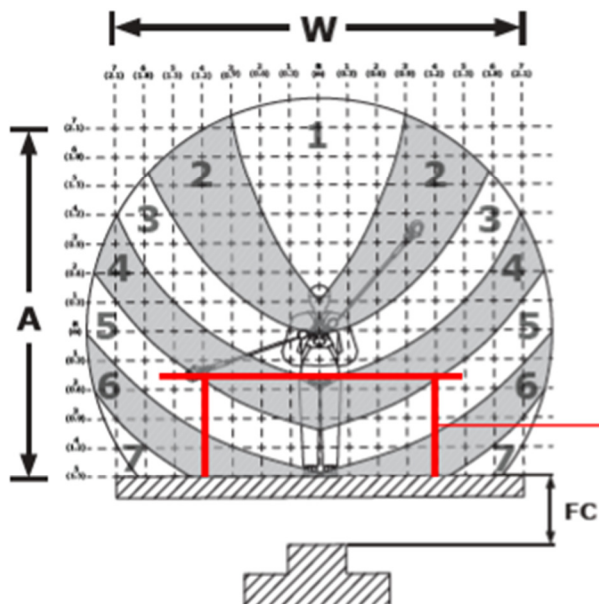

MEWP Guardrail

If worker is within 2' of their MEWP anchor point, use Column 3 for fall clearance.

If worker is between 2.1 & 4' of their MEWP anchor point, use Column 4 for fall clearance.

	Chart Area						
	1	2	3	4	5	6	7
Single-SRD Models	6.0 ft. (1.8 m)	8.0 ft. (2.4 m)	10.0 ft. (3.0 m)	12.0 ft. (3.7 m)	14.0 ft. (4.3 m)	16.0 ft. (4.9 m)	18.0 ft. (5.5 m)
Twin-SRD Models	6.0 ft. (1.8 m)	8.0 ft. (2.4 m)	10.0 ft. (3.0 m)	12.0 ft. (3.7 m)	14.0 ft. (4.3 m)	16.0 ft. (4.9 m)	18.0 ft. (5.5 m)
	Fall Clearance (FC)						

Key	
A	= Anchorage Height
W	= Maximum Work Radius
FC	= Required Fall Clearance



**Aerial Work Platforms (AWP)**

**Fall Clearance Chart #2: 221 lb. - 310 lb. (101 kg - 140 kg)**

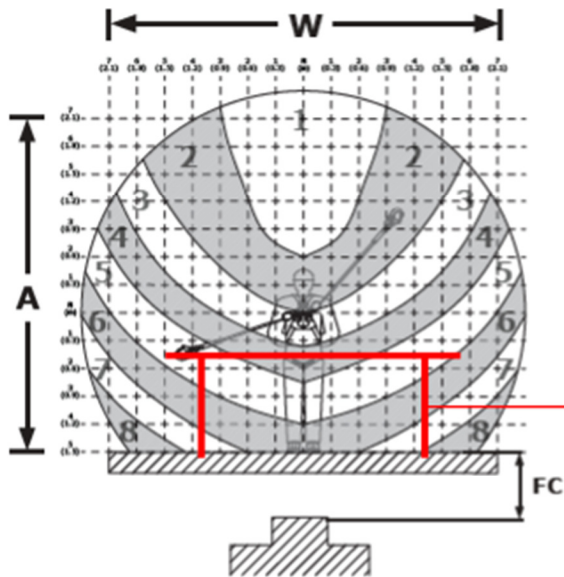

MEWP Guardrail

If worker is within 3' of their MEWP anchor point, use Column 4 for fall clearance.

If worker is between 3.1 & 6' of their MEWP anchor point, use Column 5 for fall clearance.

	Chart Area							
	1	2	3	4	5	6	7	8
Single-SRD Models	7.0 ft. (2.1 m)	9.0 ft. (2.7 m)	11.0 ft. (3.3 m)	13.0 ft. (4.0 m)	15.0 ft. (4.6 m)	17.0 ft. (5.2 m)	19.0 ft. (5.8 m)	21.0 ft. (6.4 m)
Twin-SRD Models	8.0 ft. (2.4 m)	10.0 ft. (3.0 m)	12.0 ft. (3.7 m)	14.0 ft. (4.3 m)	16.0 ft. (4.9 m)	18.0 ft. (5.5 m)	20.0 ft. (6.1 m)	22.0 ft. (6.7 m)
	Fall Clearance (FC)							

Key	
A	= Anchorage Height
W	= Maximum Work Radius
FC	= Required Fall Clearance



## Aerial Work Platforms (AWP)

**Fall Clearance Chart #3: 311 lb. - 420 lb. (141 kg - 191 kg)**

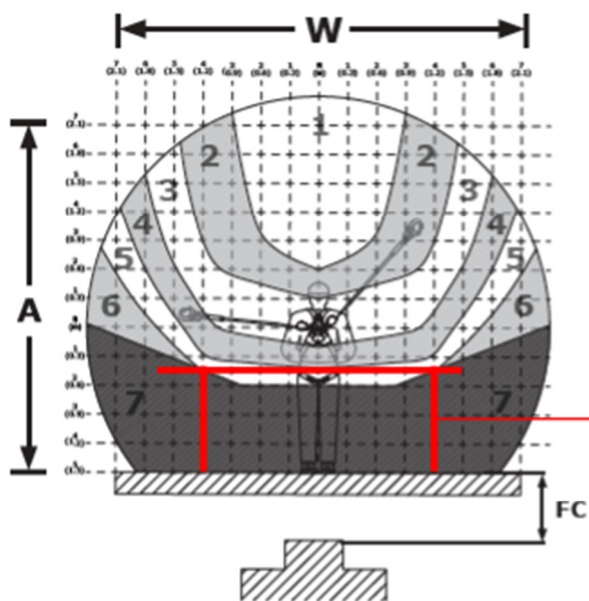

MEWP Guardrail

If worker is within 2' of their MEWP anchor point, use Column 4 for fall clearance.

If worker is between 2.1 & 5' of their MEWP anchor point, use Column 5 for fall clearance.

	Chart Area						
	1	2	3	4	5	6	7
Single-SRD Models	9.0 ft. (2.7 m)	11.0 ft. (3.4 m)	13.0 ft. (4.0 m)	15.0 ft. (4.6 m)	17.0 ft. (5.2 m)	19.0 ft. (5.8 m)	Do not connect in this area.
Twin-SRD Models	9.0 ft. (2.7 m)	10.0 ft. (3.0 m)	12.0 ft. (3.7 m)	14.0 ft. (4.3 m)	16.0 ft. (4.9 m)	18.0 ft. (5.5 m)	Do not connect in this area.
	Fall Clearance (FC)						

Key
A = Anchorage Height
W = Maximum Work Radius
FC = Required Fall Clearance

**3M**

3

## Mounted Self-Retracting Lifelines

1. This section covers retractable lifelines attached to a fixed anchor point and are non-wearable by the user such as "Ultra-Lok retractable" and similar units.
2. CEC has multiple models of mounted retractable units. This section covers common requirements for retractable units. Capacities are generally 130 – 310lbs. Some specific units allow users as low as 75 lbs. up to 420 pounds. Users above or below the listed general capacities should check the manufacturer's specifications.
3. Mounted SRLs are most effective when installed overhead and are generally installed for near vertical use.
4. Free fall situations should be limited during use of mounted SRLs.

5. Mounted SRLs with leading edge capability are permitted for horizontal use. Free fall shall be limited to 5'.

**Attachment Height, Work Zone, and Clearance Chart.**

- A. Height of the Mounted Retractable
- B. Fall Clearance Required
- C. Maximum work radius from center.

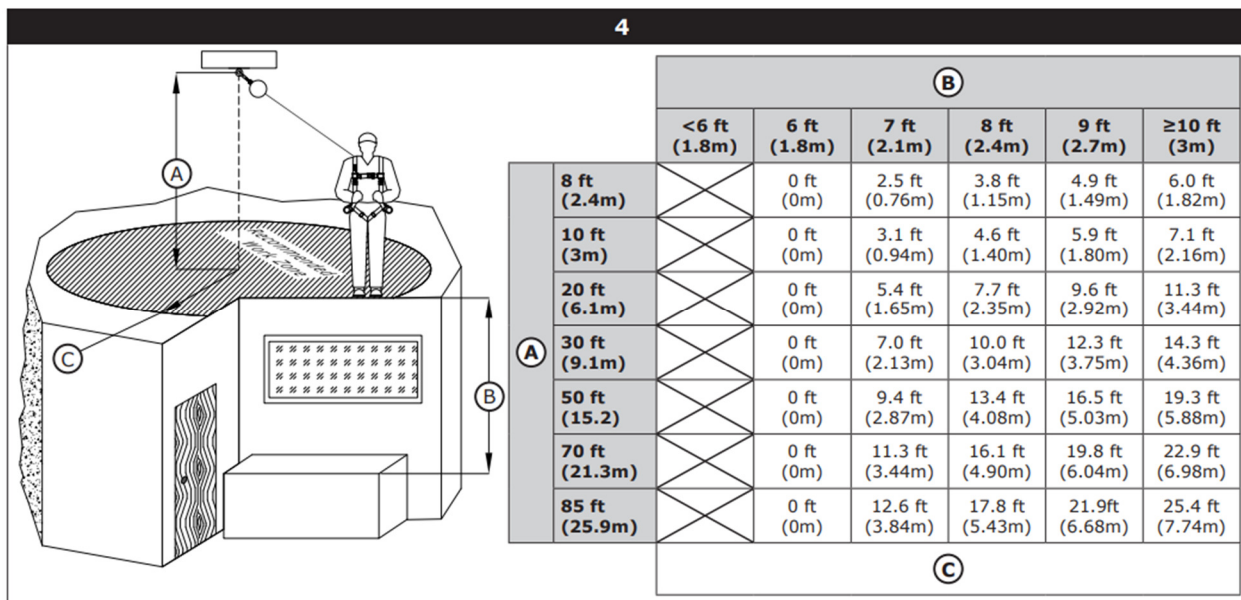

**References:**

- 29CFR1910, Subpart D, Walking-Working Surfaces, & Subpart I, Personal Protective Equipment RFR 016862A
- APA-ZZ-00365, Callaway Energy Center Lifting and Rigging Program
- DBI/SALA/Capital Safety Equipment User Guide

**FIRE PREVENTION/PROTECTION**

Intent	Eliminate potential ignition sources and control combustible materials.
Applicability	Employees – Vendors Contractors
Hazards	Burns – Trauma – Entrapment – Respiratory

**Key Point**  
Immediately report all fires to the Main Control Room.

**Fire Reporting**

1. Immediately report all fires to the Main Control Room by the following methods:
  - a. Plant Desk Phone System dial 68787
  - b. Cell Phone #573-676-8787
  - c. Plant Radio System use Plant Channel 1
  - d. Gaitronics using the following procedure: Select Plant Line 1 (DO NOT push the page button) and state the following, “Control Room Supervisor this is an emergency – pick up line 2”. Switch to Plant Line 2 and make the report.
2. When reporting fires, report:
  - a. Your name
  - b. Location of the fire
  - c. Type and extent of fire
  - d. Injured personnel, if any
  - e. Allow control room personnel to hang up and end communication.
  - f. Follow the instructions of the Control Room personnel.
3. The Control Room Supervisor will dispatch the plant fire brigade to extinguish the fire.

**NOTE**  
For control of combustible material refer to APA-ZZ-00741, Control of Combustible Materials for additional information.

**Hot Work**

1. Performance of Hot Work must be done in accordance with APA-ZZ-00742, Control of Ignition Sources.
2. Hot work includes any activity that generates a significant quantity of heat and/or showers of sparks or slag. This includes activities such as welding, cutting, grinding, brazing, open flame soldering, or other open flame work. This does not include working with a blow dryer type of heat gun, wire brushing by hand, wire brushing with power tools, or soldering with a soldering gun.

**Fire Protection Equipment**

Do not obstruct or block access to fire protection equipment. Examples include yard hydrants, hose stations, or extinguishers being blocked by temporary outage trailers or staged materials/parts. (CRs 199902753 and 199902113)

**References:**

- APA-ZZ-00741, Control of Combustible Materials
- APA-ZZ-00742, Control of Ignition Sources
- FPP-ZZ-00009, Fire Protection Training Program
- CR 199902753
- CR 199902113

**FORKLIFTS**

Intent	Provide guidance for the safe use of forklifts.
Applicability	Applies to all forklift activities.
Hazards	Falls – Equipment Failure – Dropped Material – Electrical Hazards – Explosion Hazard – Pinch Points – Crush Hazard

**Key Point**  
Only trained people can operate a forklift.

**General Safe Work Practices**

1. Only trained personnel shall operate a forklift.
2. Follow the PPE requirements listed in the PPE section of the SWPM.
3. Slow down and sound the horn at cross aisles or corners when view is obstructed.
4. Ascend and descend grades slowly. If the grade is in excess of 10 percent, drive the loaded forklift with the load upgrade.
5. On all grades, tilt the load back and raise only as far as necessary to clear the road surface.
6. Operate forklifts at speeds that will ensure a safe stop.
7. No passengers are allowed on forklifts.
8. Seatbelts must be worn if the forklift is equipped with seatbelts.
9. Do not defeat any factory installed safety device.
10. Lift only loads within the rated capacity of the forklift. Rated capacity is defined as the "load" established by the manufacturer and labeled on the fork truck. (CR 199901104)
11. The operator must be cognizant of the load capacity of the forklift.
12. Place the forks under the load as far as possible. Tilt the load back carefully.
13. Lift only stable or safely arranged loads. Use extreme caution when handling off center loads which cannot be centered.
14. While driving a forklift on a truck or trailer:
  - a. Block the wheels of the truck or trailer.
  - b. Check the floor of the truck or trailer for breaks or weaknesses prior to entry with the forklift.
  - c. The driver shall look in the direction of the path of travel.

**NOTE**  
The capacity of the forklift will decrease as the height of the load increases.

**Forklift Inspections**

1. Inspect forklifts initially prior to daily use.
2. Where forklifts are used around the clock, inspect them each shift.
3. If conditions are identified that adversely affect the safe operation of the forklift, tag the forklift with a "DANGER Do Not Use" tag, initiate actions to correct the deficiency, and do not use the forklift until it is repaired.

### **Unattended Forklifts**

1. Forklifts are unattended when the operator is more than 25 feet away from the vehicle or is not in direct view.
2. When unattended:
  - a. The forklift's load engaging means shall be fully lowered
  - b. The controls shall be neutralized
  - c. The power shall be shut off
  - d. Ensure the brakes are set
  - e. Ensure keys are removed
  - f. Block wheels if the forklift is parked on a grade
3. When the operator has dismounted and is within 25 feet and still in view:
  - a. The load engaging means shall be fully lowered
  - b. The controls must be neutralized, and
  - c. Ensure the brakes are set

### **Hoisting & Rigging with Forklift**

1. Forklifts **MUST** utilize approved and properly installed lifting attachments to hoist suspended loads (never rig directly to forks)
2. Ensure material/equipment being rigged on approved attachment does not exceed to the forklift capacity
3. Consider height of material/equipment being lifted
4. Consider how far material/equipment will be rigged from forklift mast
5. Operators of non-crane equipment used for the lifting of a suspended load (e.g. forklift, track hoe, etc.) are required to be qualified in accordance with APA-ZZ-00365 Appendix 1, Callaway Lifting/Rigging Qualification Matrix

### **References:**

29CFR1910.178, Powered Industrial Trucks  
CR 199901104  
CR 200908381

**HAND AND PORTABLE POWER TOOLS**

Intent	Provide guidance for the use of hand and portable power tools that will reduce the potential for injury.
Applicability	Any person using a hand or portable power tool.
Hazards	Cuts – Burns – Electrical Scrape

**Key Point**

Power tools present MANY hazards including electrical, sharp edges, shavings, foreign material being thrown into the air, and hydraulic or pneumatic leaks.

**General Safe Work Practices**

1. Inspect hand and portable power tools prior to use.
2. Follow the PPE requirements listed in the PPE section of the SWPM.
3. Only use in accordance with procedures or manufacturer recommendation/instructions.
4. Only personnel trained and qualified with the maintenance and operation of hand and portable power tools are allowed to operate them.
5. All electric hand and portable power tools shall be equipped with a ground prong or be double insulated.
6. A GFCI is required to be used with all electric power tools if working outdoors or working around water.
7. When battery operated power tools (drills, impacts, saws, etc.) are not in use, the batteries should be removed to prevent inadvertent actuation.
8. All power tools are required to be de-energized and placed in a safe condition if left unattended and always placed in a safe condition when not in use.
9. Grinders must have a constant pressure (a.k.a "dead man") power control switch (CR 201003842).
10. Use of the support arms for portable power drive tools (e.g. Ridgid 700 Portable Power Drive, a.k.a. "Power Pony") to resist the high handle forces developed during use and prevent losing control of the tool.
11. Type 1 grinding wheels are not to be used.

**References:**

29CFR1910.242, Hand and Portable Powered Tools and Equipment  
 29CFR1926.302, Use of Electric Cords for Hoisting or Lowering Tools  
 29CFR1910.333, Selection and Use of Work Practices  
 29CFR1910.269.I.2.II, Use of Plugs and Electrical Cords  
 29CFR1910.269.I.4, Use of Hydraulic and Pneumatic Tools  
 T68 MTIP and T68 MTIH  
 CR 201003842

**HAZARDOUS ATMOSPHERES**

Intent	Provide guidelines to reduce the potential for injuries and illness associated with Hazardous Atmospheres
Applicability	Applies to any situation involving a hazardous material that could result in a hazardous atmosphere.
Hazards	Oxygen Deficiency – Hazardous Gases – Hazardous Vapors – Toxic Atmospheres – Flammable Atmospheres

**Key Point**

Hazardous Atmospheres can occur anywhere you breathe. They are not limited to confined spaces.

**General Statement**

1. In each case, individuals and supervisors must ensure hazards are identified and appropriate precautions are taken.
2. Consult the following information to aid in identifying and controlling hazardous atmospheres:
  - a. Specific work procedures
  - b. Safety Data Sheets (SDSs)
  - c. Hazardous Material Permit
  - d. Hazardous Material Labels
  - e. Safety and Chemistry personnel if questions arise
3. If it is determined that the potential exists for a hazardous atmosphere, contact Chemistry for an evaluation.

**CAUTION**

- Immediately Evacuate area and contact Chemistry when an atmospheric hazard alarm sounds.
- Do not mix cleaners or other chemicals unless chemical compatibility has been determined. Mixing some chemicals including some common cleaning agents can result in generation of toxic gases or a serious chemical reaction.

**General Safe Work Practices:**

1. **Toxic Atmospheres** - Toxic atmospheres may be caused by the use of a chemical substance in the area where work is performed, the exhaust of an internal combustion engine, the byproducts of welding or cutting, painting with a paint that produces toxic vapors, or any other situation where personnel may breathe in a toxic vapor that may be hazardous to their health.
2. **Oxygen Deficient Atmospheres** - Oxygen deficient atmospheres may be caused by displacement of oxygen due to the presence of a gas or by a chemical reaction that consumes oxygen. Common gases that will displace oxygen include nitrogen, argon, and carbon dioxide.
3. **Explosive/Flammable Atmospheres** - Explosive/Flammable atmospheres occur if the concentration of a flammable gas or materials nears the concentration necessary to ignite/explode.
  - a. Air eductor horns must be grounded
  - b. Electrical blowers must be intrinsically safe

4. **Prior to working in a potentially hazardous atmosphere:**
- a. Identify ALL hazardous substances involved with the work task and being used in the immediate area.
  - b. Know the potential hazards associated with the atmosphere.
  - c. Consider the effects of mixing chemicals.
  - d. Be aware of the signs/symptoms of exposure to the hazardous atmosphere.
  - e. Be aware of actions to take if signs/symptoms are noted.
  - f. Contact medical or the Control Room for assistance if the signs/symptoms of the hazardous atmosphere are noted.
  - g. In some cases, specific Personal Protective Equipment may be required to protect the worker (inhalation and absorption hazards should be considered). Follow the PPE requirements listed in the PPE section of the SWPM.
  - h. Where hazardous chemicals/materials are used, stored, or disposed of in the workplace, use of engineering controls (e.g. natural, forced, or local exhaust ventilation) may be required to eliminate or reduce airborne concentrations of hazardous substances.

**References:**

CDP-ZZ-01100; Atmospheric Hazard Control Program

APA-ZZ-00802; Confined Space Program

29CFR1910, Subpart G, Occupational Health and Environmental Control

29CFR1910, Subpart H, Hazardous Materials

29CFR1910, Subpart I, Personal Protective Equipment

29CFR1910, Subpart Z, Toxic and Hazardous Substances

**HEAT STRESS**

Intent	Provide guidance to prevent and/or reduce the probability of heat stress to workers.
Applicability	Applies to all workers performing work in hot environments and/or working in protective clothing.
Hazards	Heat Cramps – Fainting – Heat Exhaustion – Heat Stroke

**Key Point**

Heat illness sneaks up on you. At first you feel tired, then dizzy, then worse. When working in hot areas, do not push to finish when you get an exhausted feeling. Your body is sending you a message.

**General Safe Work Practices**

1. Reference Appendix 1 of the SWPM "Callaway Heat Stress Guidance".
2. The work group supervisor is responsible for obtaining heat stress stay times.
3. The work group supervisor is responsible for keeping track of workers condition in heat stress conditions and to enforce stay times and recovery times.
4. If you will be exposed to heat stress conditions, you should consider the following heat stress hygiene practices:
  - a. Consider the workers' personal risk factors.
  - b. Consider engineering controls.
  - c. Contact Safety for assistance in planning heat stress jobs if necessary.
5. A recovery time calculation must be done if personnel must re-enter the heat environment after their initial entry. This formula can be found in the Heat Stress Guidance.

**References:**

Callaway Heat Stress Guidance (SWPM, Appendix 1)

**HEXAVALENT CHROMIUM**

Intent	Reduce the potential exposure to Hexavalent Chromium to no more than 5.0µg/m3 8 hour time weighted average.
Applicability	Applies to all work activities with a potential to expose workers to Hexavalent Chromium.
Hazards	Exposure to Hexavalent Chromium.

**Key Point**

Stainless steel welding has been identified as having the highest potential for worker exposure. Work activities involving chromate based paints also have the potential for worker exposure.

For all Information concerning Hexavalent Chromium refer to Management Instruction ES-REG-216, Hexavalent Chromium found on Scholar under Safety.

**References:**

- 29CFR1910.1026, Chromium (VI)
- 29CFR1926.1126, Chromium (VI)
- ES-REG-216 - Hexavalent Chromium

**HYDROLASING/WATER BLASTING EQUIPMENT (3000 PSI OR GREATER)**

Intent	Alert operators of the equipment to the dangers associated with hydrolazing and water blasting equipment.
Applicability	Applies to all work activities that involve the use this type of equipment.
Hazards	Lacerations from high pressure water jets and induction of air into the bloodstream.

**Key Point**

Working with hydrolazing and water blasting equipment can pose an extreme hazard to anyone hit by the water jet in a close proximity of the nozzle or any pinhole leak in fittings or hoses.

**General Safe Work Practices**

1. Only personnel familiar with the maintenance and operation of hand and portable power tools are allowed to operate them.
2. Follow the PPE requirements listed in the PPE section of the SWPM.
3. Never modify equipment in any manner without the manufacturer or engineering approval.
4. Only use hydrolazing or water blasting equipment in accordance with procedures or manufacturer recommendations/instructions.
5. All equipment must be inspected, and any defects repaired prior to using the equipment.

**CAUTION**

The control gun length must never be shortened in a manner that would allow the water jet to hit any part of the operator's body.

**References:**

None

**JOB SAFETY BRIEFINGS**

Intent	Provide guidance for Job Safety Briefings
Applicability	Conduct a job safety brief before all activities that have the potential to challenge plant reliability, nuclear, or personnel safety.
Hazards	Various

**Information on Job Safety Briefings can be found in APA-ZZ-0100B; Job Briefs**

1. **Purpose of Job Briefings:**
  - a. To ensure understanding of task scope, precautions and sequence
  - b. To provide an opportunity to ask questions or raise concerns
  - c. To prevent events by using Operating Experience and Human Performance Tools to identify similar precursors & weaknesses
  - d. To identify hazards and develop eliminating/mitigating strategies
2. Utilize form CA2423 to perform Job Briefs.
3. **The following must be fully understood by all job participants before work is to be performed:**
  - a. Work procedures used and Safe Work Practice Manual as required
  - b. Special Precautions
  - c. Energy source controls
  - d. PPE required
  - e. Hazards associated with the job

**References:**

29CFR1910.269(c), Electric Power Generation, Transmission and Distribution  
 APA-ZZ-0100B, Job Briefs  
 CA2423

**LABORATORY SAFETY**

Intent	Provide guidance to reduce the potential for injuries associated with work in laboratories.
Applicability	Applies to all Chemistry and Radwaste laboratories.
Hazards	Chemical Splash – Chemical Burns – Eye Injuries

**Key Point**  
Chemicals can burn, scar, or kill you. Always take proper precautions.

**NOTE**  
Beverages are permitted in the administrative areas of the Cold Lab and Water Treatment Plant Lab and may be consumed in these areas only.

**General Safe Work Practices**

1. Do not eat, drink, smoke, chew gum, or apply cosmetics in laboratories.
2. Do not store food, beverages, or eating utensils in laboratories.
3. Wash hands thoroughly, often, and prior to exiting laboratories.
4. Promptly flush skin with water that comes in contact with hazardous chemicals.
5. Promptly flush eyes with water for at least 15 minutes, when your eyes are contacted by hazardous chemicals.
6. Promptly remove any personal clothing contaminated with chemicals.
7. Do not smell or taste hazardous chemicals.
8. Always wear appropriate personal protective equipment.

**References:**

CDP-ZZ-00710, Laboratory Chemical Hygiene Plan

**LADDERS**

Intent	Provide guidance to reduce the potential for injuries associated with the use of fixed and portable ladders.
Applicability	Applies to all work activities that involve the use of ladders.
Hazards	Falls – Slips/Trips – Falling Objects – Pinch Points Structural Failure

**Key Point**

Inspection of ladders prior to use and properly securing ladders will reduce the potential for injury.

**Key Point**

When ascending/descending fixed, scaffold, or portable ladders where the climber reaches 20 feet or above, from the climbers' feet to the platform level/below, fall protection is required. Fall Protection can consist of an installed cage, center ladder safety device, or retractable lanyard.

**General Safe Work Practices**

1. Inspect all ladders prior to each use. If damaged or degraded, withdraw ladders from use and tag with a “DANGER Do Not Use” tag. Take actions to get the ladder repaired or removed from service.
2. Always maintain 3 points of contact while ascending or descending a ladder
3. Inspection of ladders prior to each use shall include the following, at a minimum:
  - a. All rungs and steps are free from oil, grease, obstructions, debris, etc.
  - b. All fittings are tight.
  - c. Spreaders or other locking devices are in place, if applicable.
  - d. Non-Skid safety feet are in place, IF applicable.
  - e. No structural defects, all support braces are intact.
  - f. Ensure weight limits are marked and understood (portable ladders).
4. When moving ladders, care must be taken not to strike personnel or equipment. If necessary, two people should move the ladder.
5. When working from any ladder fall protection is required when working:
  - a. Torso outside the rails of the ladder
  - b. Above handrails
  - c. Leaning back on ladder or leaning forward when facing away from the ladder
6. When using ladders near unguarded edges ensure that base of ladder is far enough away from edge to prevent falls.

### **Portable Extension/Straight Ladders**

1. Portable extension or straight ladders shall be placed so the distance from the foot of the ladder to the point where the upper portion of the ladder is supported has a ratio of 1:4 (base-to-height). If this is not achievable, then the ladder must be secured at the top and/or bottom as appropriate. Securing of portable extension or straight ladders shall be performed as follows:
  - a. At the bottom prior to climbing the ladder or be held by another worker to prevent slipping.
  - b. If it is to be left in place, the ladder should be secured as high as possible.
  - c. If it is preferable that the ladder be secured near the bottom and near the top.
2. Where possible, the upper end of portable extension or straight ladders needs to extend a minimum of 36 inches above the platform.

### **Portable Step Ladders**

1. Do not use the top of a stepladder or the step immediately below the top of the stepladder as a step. (This does not apply to any step stand under 4 feet that is designed by the manufacturer to stand on the top step.)
2. Ladders shall not be placed in front of doorways unless the door is blocked open, locked, or guarded.

### **Use of Ladders**

1. Ladders shall be used by only one person at a time unless it is a step ladder that is designed to allow one person to work off of each side.
2. When ascending/descending, face the ladder and use both hands. Do not carry tools or materials in your hands when climbing.
3. Ladders must only be used as designed. Ladders shall not be used as platforms or be spliced together unless designed to do so.
4. Portable ladders with conductive side rails or metal reinforcements shall not be used where energized electrical circuits can be contacted.
5. When overhead un-insulated conductors are present, care must be taken to maintain a safe clearance distance between the ladder and the overhead conductor.
6. Rungs and steps should be kept free of grease, oil, ice, and snow when in use.
7. Adjustment of extension ladders must only be done from the ground.
8. Portable ladders must be stored in their designated storage locations when not in use.

### **References:**

29CFR1910, Subpart X, Stairways and Ladders

29CFR1910.25, Portable Wooden Ladders

29CFR1910.333, Selection and Use of Work Practices

29CFR1910.269.H.3, Use of Conductive Ladders Near Energy Sources

29CFR1910.27, Fixed Ladders

**LEAD**

Intent	Reduce the potential for exposure to lead when working with materials that contain lead.
Applicability	Applies to activities associated with material that contains lead.
Hazards	Exposure to lead (inhalation or ingestion)

**Key Point**

When working with materials that contain lead, care must be taken to ensure the lead does not become airborne. The primary hazard involves inhalation of lead material.

**General Safe Work Practices**

1. Prior to performing work activities that will disturb paints, contact Ameren Corporate Industrial Hygienist or other qualified inspector to have materials sampled to rule out the presence of lead. Coating Engineer can be contacted for assistance with coatings known to contain lead.
  - a. Activities likely to disturb lead based paint include (but not limited to) grinding, welding, and sanding.
2. The following are areas where lead is present at Callaway Energy Center:
  - a. Lead shielding
  - b. Lead based paint – including some of the pale green structural steel paint
  - c. Lead bus bars in battery rooms
  - d. Primer paints on the main transformers
  - e. Lead containing rad flex penetration seals (CR 200000487)
  - f. Lead may also be present in the silver paint on valves in the turbine building
  - g. Lead shims are installed around the Intake bypass pipe sleeve
3. Industrial Hygienists have reviewed many of the lead activities at Callaway Energy Center and are available for assistance. The lead activities we have are low risk as long as they are handled correctly. Many provisions of the Lead Standard such as Medical Monitoring do not apply to the activities we are likely to encounter.

**CAUTION**

Red primer paint and silver valve body paint is always suspect and may contain lead.

4. If you come into contact with red primer paint or silver valve body paint and need to remove the paint, stop the work and contact your supervisor to assist in getting the material sampled.

**CAUTION**

Lead materials can enter your body by inhalation and ingestion. Lead is not absorbed through your skin.

5. Work with lead containing materials where the potential exists to exceed the PEL for lead for Ameren employees requires a Compliance Plan be written and implemented prior to the job starting. The requirements of a Compliance Plan can be found in Corporate Safety & Health management instruction ES-REG-211, Lead. Prior to working with or handling lead the following training is required: a) General Lead Handling Training Requirements (CR 200104641) and b) know the contents of 29 CFR 1910.1025, Lead or 29 CFR 1926.62, Lead and associated appendices for the applicable standard.

**RAD FLEX AND HIGH DENSITY LEADED ELASTOMER (HDLE) PENETRATION SEALS COMPLIANCE PLAN**

1. Prior to starting work contact Safety for help preparing a Compliance Plan for the specific project.
2. Lead penetration seals may be removed via a slow drilling process. This has been performed in the past without exceeding any exposure limits and can be performed in the same manner summarized below without respirator or monitoring required.
3. If you must deviate from the below plan, contact Safety.
  - a. Utilize slow drilling process.
  - b. Local exhaust ventilation with HEPA filters as close as possible to the actual lead material being drilled.
  - c. Isolate area with CAUTION tape and sign stating "Warning, lead work area, poison, no smoking or eating".
  - d. Follow the PPE requirements listed in the PPE section of the SWPM.
  - e. Dispose of lead penetration and material, protective clothing, etc. in an accumulation area controlled by Chemistry.
  - f. Equipment such as drills, bits, etc. can be wiped free of lead and released from area.
  - g. Use a bag below the penetration to catch material and ensure this area is isolated with CAUTION tape also.
  - h. Wash hands, face, arms, etc. each time when exiting area to keep from inhaling this later while eating, etc.

## **Handling Uncovered Lead Bricks Lead Compliance Plan**

Prior to the commencement of a lead project, the following plan must be met. If it is not possible to complete the work in the manner described below, stop and consult with your Supervisor & Safety.

1. **Description of the job:**
  - a. Moving/handling uncovered lead bricks. The lead handling task is not to exceed 30 minutes (this means the actual act of lead movement / handling).
2. **Equipment to be used:**
  - a. Rags and water or similar for wet wiping bricks prior to movement
3. **Material Involved:**
  - a. Uncovered lead bricks
4. **Controls In Place:**
  - a. Lead Safety Training CBT is required, course is T68.2897 6.
  - b. Disposal of Rags, outer gloves, Tyvek, or Orex (clothing that came into contact with the lead) need to be disposed of as lead waste.
  - c. Follow RP guidance for any radiation contamination issues during disposal in the RCA).
  - d. Contact Chemistry for assistance with lead disposal questions.
  - e. No cutting, grinding, sanding, or use of abrasive materials on the lead surfaces.
5. **Crew Size and Responsibly:**
  - a. This compliance plan is for work groups of 6 or less workers involved in the direct handling of uncovered lead bricks.
  - b. The work group supervisor is responsible for the execution and oversight of this lead compliance plan.
6. **Operating Procedures and Maintenance Practices:**
  - a. Wet wipe the bricks prior to handling to remove any dust or lead oxide.
  - b. If the work is in a radiological contaminated area, contact RP for additional direction on contamination controls.
7. **Protective Clothing To Be Used:**
  - a. Standard Callaway PPE for the area where work is being performed should be utilized. PPE for lead protection should include:
    - 1) Impervious outer gloves (nitrile for example) over leather or equivalent
    - 2) Tyvek or Orex coverall over street clothes or modesty garments

### **References:**

29 CFR 1910.1025, Lead

29 CFR 1926.62, Lead

Ameren Safety and Health Management Instruction – Lead ES REG 211

CR 200000487

CR 200104641

## LEGIONELLA BACTERIA

Intent	Reduce the potential for developing illness related to legionella bacteria.
Applicability	Applies to personnel who enter steam environments.
Hazards	Legionnaires Disease – Pontiac Fever (flu like symptoms)

### **Key Point**

Legionella bacteria are common in water systems. It can make you sick if it is breathed deeply into the lungs.

### **General Safe Work Practices**

1. The following are areas of concern for Legionella Bacteria:
  - a. Cooling Tower at power
  - b. UHS Cooling Tower areas where visible mist is present (may include rooms, fill area, and basin)
  - c. Temporary Cooling Tower by Control Building when operating and ascending the ladder
  - d. Water boxes and piping with steam leak-by
  - e. Areas where raw water mist can be inhaled

### **NOTE**

The concern for Legionella Bacteria is primarily the raw water systems.

### **NOTE**

Personnel who have health problems that affect the immune system could be more susceptible to Legionnaires Disease or Pontiac Fever.

2. Personnel who must work in these areas where there is a potential for inhaling mists or aerosols will follow these precautions:
  - a. Minimize the time spent in these areas.
  - b. Wear at least a half face respirator with a HEPA or TYPE H filter.

### **References:**

ES-ADM-107: Microbial Control Plan for Building Water Systems

Guidelines for Dealing with Hazards in the Workplace: Legionella

**MANUAL MATERIAL HANDLING (LIFTING AND BACK SAFETY)**

Intent	Provide guidelines to reduce the probability of injuries associated moving material.
Applicability	Applies to all material handling and storage activities.
Hazards	Back Injuries – Pinch Points – Falling Objects

**Key Point**

Most lifting accidents are due to improper lifting methods. All manual lifting should be planned and safe lifting procedures followed including not lifting over 50 pounds without assistance. For more detailed information on material handling and the use of material handling equipment see APA-ZZ-00366, Callaway Material Handling Program.

1. When cutting banding straps from material, keep body out of the line of fire of the strap containing stored energy by placing yourself perpendicular to the directional routing of the strap prior to removing banding.
2. Loose stored material secured by items such as banding, straps, and rope can unexpectedly shift upon removal of securement method. ALWAYS position your body out of the line of fire of the direction the material could shift or fall, regardless of the probability.
3. Cribbing used to elevate material for lifting operations should, at a minimum, be flush with the most outer edge for multi-item loads prior to removing securing methods (i.e. banding, straps, rope, etc.). For single material items, cribbing shall be sufficient for stabilization of the material stored.
4. When removing securing method (i.e. banding, straps, rope, etc.) from palletized material that could shift or fall, ensure the body is kept out of the line of fire.

**References:**

APA-ZZ-00366, Callaway Material Handling Program

**OFFICE SAFETY**

Intent	Reduce the probability of accidents and safeguard hazards for all office areas.
Applicability	All employees at the Callaway Energy Center
Hazards	Slips – Trips – Falls – Improper Lifting – Hazardous Chemicals – Poor Lighting or Glare – Poor Workstation Layout/Design – Poor Housekeeping

**Key Point**

Office spaces require attention to ergonomics, power cords, etc. to minimize exposure to injuries.

**General Safe Work Practices**

1. Office arrangements should allow easy egress under emergency conditions.
2. Aisles (minimum of 36” width clearance) exits, stairwells, and doorways should be kept clear at all times.
3. Keep desk, file, or cabinet drawers closed when not in use.
4. To prevent tipping of file cabinets, do not open more than one drawer at a time.
5. Wherever possible, store large, heavy objects on lower shelves and smaller, lighter objects on top shelves.
6. All chair legs must be kept on the floor when in use.
7. Do not run in hallways or up and down stairs. Use handrails where provided.
8. Utilize Core 4 tools when carrying objects up/down stairs. Minimize risk of falling by using equipment, peer help or elevators.
9. Do not stand or climb on office furniture.
10. Do not prop feet on tables or desk.
11. Ensure paper cutter blades are in the locked position when not in use.
12. Wrap sharps (e.g. razor blades, utility blades, metal pieces), broken/cracked glass, brittle plastic objects, or other material that may break and produce a sharp or rough edge in corrugated cardboard, secured with tape, and marked with the condition and material type (e.g. broken glass) before placing in a trash container.
13. At the end of each shift, shut off and/or unplug small appliances (i.e. toaster ovens, space heaters, etc.).

**Ergonomics** – For any questions, see the ergonomics section of the SWPM.

**Chemical Hazards** – For any questions, see the Chemical hazards section of the SWPM.

**References:**

CR 201802529

**PERSONAL PROTECTIVE EQUIPMENT (PPE)**

Intent	Eliminate or reduce the severity of injury by appropriately using personal protective equipment
Applicability	All employees at the Callaway Energy Center
Hazards	Eye/Face Injuries – Head Injuries – Foot Injuries – Hearing Loss – Chemical Burns

**Key Point**

PPE will not prevent accidents. However, it may reduce the severity of injuries resulting from accidents. It may save your sight. It may keep you alive.

**General Statement**

1. The guidelines for selecting and using personal protective equipment are appropriate in most situations. However, the minimum equipment listed may not always be adequate for the job. In each case, the individual and supervisor must ensure the appropriate personal protective equipment is used.
2. Designated break areas any designated break areas in a plant or operating area must be posted with a sign stating “Designated Break Area, CAUTION: Personal Protective Equipment may still be required due to ongoing work in the area” or similar wording. The Safety Supervisor must approve break areas in plant operating areas.
3. Ensure PPE is maintained per manufacturers recommendations, keeping PPE in a sanitary, reliable condition, and do NOT use if damaged, altered, or otherwise defective.

**NOTE**

Emergency response personnel are not required to procure PPE if doing so will delay their response in an actual emergency situation. They are encouraged to don the appropriate PPE, if available, and to avoid exposing themselves to any hazardous situations from the lack of PPE. This includes groups such as Ambulance Staff, Site Medical Staff, and MERT.

**Standard PPE**

**NOTE**

Visitors (e.g. self-assessment, audits, INPO, etc.), even if they are badged, will not be required to wear safety shoes or have gloves on person for plant tours, provided that they do not go in areas of material handling, perform electrical work, work with hazardous chemicals, or perform other physical work activities.

Vendors making deliveries and to service equipment outside the Protected Area are not bound to Safe Work Practices Manual requirements and fall under their organizations Safety Guidelines.

Standard PPE is not required when traversing between lockdown gates 48 and 49 and the Comm. Corridor. Any work performed in the area requires standard PPE and PPE for the specific job task.

**NOTE**

Personnel entering the lockdown fence Plant North of the Turbine Building for the sole purpose of vehicle retrieval, not to be beyond the external emergency shower station and not within the Transformer Exclusion Zone, shall be allowed to enter and immediately proceed to the vehicle location without donning all standard PPE as long as the area has been accessed and there is no work being performed in the immediate vicinity or other hazards present, as identified by worker or SWPM that would require PPE to be worn.

1. When entering the PPE zone (e.g. lock-down fence), entering operating areas of the plant, and when outdoors performing physical work activities as listed in the PPE table, all personnel including visitors, must wear the following basic PPE:
  - a. Shirts with sleeves
  - b. Full length trousers
  - c. Hard Hat – Class E/G or Class A/B
  - d. Safety Glasses – ANSI Z87.1 with approved attached side shields
  - e. Safety Shoes – New Standard ASTM F2413-05 C75/I75 or old Standard ANSI Z41 C75/I75 shoes. ASTM number can be any year that standard was in place as long as it meets the current standard.
  - f. Gloves as required by PPE chart WHEN performing work

**NOTE**

**Hard hats are NOT to be worn:**

- Behind the main control panels in the Plant Control Room
- Inside the rails of the spent fuel pool
- Inside the rails of the refueling pool while water is in the upper cavity
- Accessing and working on the polar crane
- WHEN entering the annulus

During Refueling Outages, hardhats and safety glasses are not required while aligning CET instrument columns and CRDM drive shafts.

When moving Nuclear Fuel, safety glasses are not required past the reactor cavity and spent fuel pool FME checkpoint as long as no other work is present.

2. Operating areas of the plant include, but are not limited to, the following:
  - a. UHS
  - b. Demin building
  - c. Circ & Service
  - d. Water Treatment Plant
  - e. Fire Pump House
  - f. CWCCS
  - g. Cooling Tower
  - h. ESW Building (Operating Side)
  - i. Intake
  - j. Gas Yard
  - k. Switch Yard

3. For entering the following areas, safety glasses, safety shoes, shirts with sleeves and full length trousers when required. Hard hats are required to be worn in addition if there is a potential for a head bump hazard, falling or flying objects, or electrical contact.
  - a. Shops
  - b. Warehouses
  - c. Labs
  - d. ISFSI
  - e. HSB
4. Follow the PPE requirements for performing work in the following areas as listed in the PPE table. Hard hats are not required to be worn in the following areas unless there is a potential for head bump hazard, falling or flying objects, or electrical contact.
  - a. Administrative/Office Areas (e.g. control rooms, service building, etc.)
  - b. Break areas, Cafeterias, Bathrooms, Locker Rooms
  - c. Shops
  - d. Warehouses
  - e. Labs
  - f. ISFSI
  - g. HSB
5. When working around rotating or reciprocating machinery, observe the following precautions:
  - a. Ensure gloves, ties, hair, and loose clothing does not become entangled in equipment. Button or properly roll up long sleeves, tuck in shirt tails, remove or tuck in ties.
  - b. Wear badge lanyards of breakaway-type material. Secure to clothing to keep it from hanging loosely.
  - c. Security lanyards may be removed from around the neck provided they are controlled and remain on the person's body (i.e. in pants pocket, etc.).

### **Chemical Protection**

1. When working with chemicals (acids, corrosives, irritants, etc.), the PPE required to be worn is basic PPE plus any additional PPE listed in the Hazmat permit.
2. If working with more than one chemical, the most conservative PPE from the Hazmat Permits shall be worn.
3. When working on batteries follow the PPE requirements listed in the PPE chart of the SWPM.

### **Eye and Face Protection**

**NOTE**

Safety glasses should be 1 piece or lenses need to be secured at 2 points (i.e. top and side). Glasses that are not 1 piece or enclosed lenses are not allowed in FME 1 areas without additional measures.

1. Do not wear dark tinted or shaded glasses inside that reduce light unless transiting through a building or required by the job (examples include using welder helper glasses or working in direct sun light).

2. If face shields are worn, goggles must be used under the face shield to protect the eyes. Goggles is a generic term and there are several trade names for eye protection that meet the same level of protection and are considered to be interchangeable. The goggles, unlike safety glasses, are designed to cover the eye sufficiently to prevent any particles or dust from entering the eye. Chemical goggles are designed to prevent any liquid from entering the eye. Chemical goggles can be used for all applications, but dust goggles may not be used for chemical protection.
3. Eye protection is required under welding shields when chipping, cutting, brushing, etc.
4. Clean and inspect eye/face protection and replace if damaged.
5. Hard hats and safety glasses will be used until self-contained anti contamination bubble hoods, delta suits, or powered face shields are in use and again when they are not in use. The cognizant Supervisor will ensure:
  - a. That all overhead work above the work crew is suspended during the use of the Power Visor.
  - b. Measures will be taken to control and minimize associated head hazards at the job site, and to minimize overhead hazards from work not associated with the job, particularly from falling objects.
  - c. Each worker is individually briefed on this variance and the safety issues involved.
  - d. If overhead hazards are identified to exist after the job has started that were not specifically evaluated prior to the job starting, the job shall be stopped immediately.

### Foot Protection

#### NOTE

Visitor will not be required to wear safety shoes for plant tours provided that they do not go in areas of material handling, perform electrical work, work with hazardous chemicals, or perform other physical work activities.

1. Safety Shoes are required in PPE areas and when performing physical work.
2. Over ankle lace up boots are highly recommended especially if your job requires walking on uneven surfaces such as outside, or in congested piping areas that have support plates present. This type of boot provides superior support to the ankle area and will reduce the probability for ankle injuries.
3. Vendors/Contractors will wear safety shoes in accordance with their contract. Exceptions to the safety manual will be evaluated by Safety.
4. For office/administrative areas, wear appropriate shoes that minimize potential for slipping or tripping. The following types of shoes do NOT meet the above criteria:
  - Open toed shoes
  - Shoes with an open heel
  - Shoes with a heel height greater than 2"
  - Shoes with a heel that tapers to a point smaller than the size of a quarter
5. For certain tasks, wear specific required protective footwear such as chemical resistant boots or metatarsal protection.
6. All footwear shall have sufficient sole tread to provide skid/slip resistance.
7. Workers are permitted to enter the protected area when prescribed a medical protective boot. Access to areas where safety toed shoes are required is not permitted with a medical protective boot. Work requiring safety toed shoes shall not be performed while utilizing a medical protective boot.

## Hand Protection

### NOTE

Visitors will not be required to have gloves on person for plant tours provided that they do not perform material handling, perform electrical work, or perform other physical work activities.

1. Ensure hand protection is carried on person whenever physical work may be performed. Appropriate gloves per the PPE chart are required whenever potential hazards to the hands exist. Some examples include but are NOT limited to the following: Cut hazards, abrasion hazards, thermal hazards (burns), chemical hazards, puncture hazards, and tool use or material handling where the hands may strike objects, be struck by objects, or pinch hazards exist. Examples include, but are NOT limited to, scaffold building, handling lumber, wood, sheet metal, beams, pipes, angle iron, rebar, utilizing clamps, and manual valve operation.
2. Appropriate hand protection (gloves) shall be worn any time physical work is performed in accordance with the PPE chart.
3. The only exceptions to wearing gloves while performing physical work in accordance with the PPE chart is:
  - a. When fine manipulation is required and there is NOT a potential for cuts, punctures, heat or cold, hazardous material/chemicals, and electrical contact.
  - b. When gloves have the potential to become entangled in rotating equipment (e.g. lathe work, when hand is in the hazard zone of a milling machine, etc.) The hazard zone is the area where loose articles of clothing, gloves, etc. can become entangled in rotating equipment.
4. While working in radiological contaminated areas appropriate hand protection is required in addition to RP gloves when physical work is performed in accordance with the PPE chart.

## Hearing Protection

### NOTE

Visitors will not be required to wear hearing protection while communication headsets are in use.

1. Hearing protection must be worn in posted areas.
2. Hearing protection may be removed intermittently for communications.
3. When working outside or in other areas, wear hearing protection when background noise makes normal conversation difficult.

## Head Protection

### NOTE

The classification Type I – Class E or Class E/G and old classification Class B and Class A/B hard hats provide impact and electrical protection.

1. Wear ANSI approved classification Type I – Class E or E/G, old classification Class B or Class A/B hard hats. Class C hard hats are available for welders. Class A hard hats may be used in limited situations such as special hard hats with air powered face shields.
2. Do not alter the hard hat's suspension and shell.
3. Do not use paints, solvents, chemicals, adhesives, or petroleum products on hard hats, unless approved. Small stickers are acceptable as determined by the dress code policy.
4. Frequently clean and inspect hard hats and replace if damaged.
5. Do not wear anything under the hard hat unless it is designed or approved for use under a hard hat (e.g. welding, protective skull caps, protective clothing hoods and/or winter liners).
6. Hard hats are required to be worn with the bill facing forward unless required to attach a face shield or similar PPE or for a specific job or task. When the specific job or task is completed, the hard hat must be worn with the bill facing forward.
7. If hard hats are worn backwards, then the suspension must be reversed.

### NOTE

Safety glasses are not required to be used with the Power Visor Face shield as the design of the Face Shield meets the ANSI Z 87.1 eye protection standard.

### NOTE

Hard hats shall be inspected prior to each use by the user. Inspection shall include the shell and suspension to identify defects such as cracks, excessive wear, broken components, and UV degradation. Replace hardhats every 5 years from the date of issuance. The suspension should be replaced every year.

When operating equipment such as forklifts, telehandlers, tracked vehicles, vehicles, and cranes with solid overhead protection, hard hats are not required, provided no head injury hazards exist. Hard hats must be donned when exiting the overhead protection area of equipment.

8. Hard hats and safety glasses will be used until bubble hoods, delta suits, or powered face shields are in use and again when they are not in use. Upon supervisor approval, hard hats and safety glasses may be waived for use with bubble hoods, delta suits, or powered face shields for low energy processes that do not pose hazards to the eyes from impact (such as cleaning, use of low pressure water rinse, etc.). Eye protection may NOT be waived in conjunction with processes that present hazards from impact to the eyes. In these cases, ANSI approved eyewear is required. The cognizant Supervisor will ensure:
  - a. That all overhead work above the work crew is suspended during their use.
  - b. Measures will be taken to control head and eye hazards at the job site, and to minimize overhead hazards from work not associated with the job, particularly from falling objects.
  - c. Each worker is individually briefed on the safety issues involved.

### Step 8 Cont'd

- d. If overhead or eye hazards are identified to exist after the job has started that were not specifically evaluated prior to the job starting, the job shall be stopped immediately.

### Hot Work

**NOTE**

FR coveralls are required to be worn for hot work in radiological contaminated areas

Hot work includes any activity that generates a significant quantity of heat and/or showers of sparks or slag. This includes activities such as welding, cutting, grinding, brazing, open flame soldering, or other open flame work. This does not include working with a blow dryer type of heat gun, wire brushing by hand, wire brushing with power tools, or soldering with a soldering gun.

### Containment Access

The following PPE is to be used for accessing containment:

1. Safety Glasses, Safety shoes are required to be worn from RP access to the approved dress out area of the Aux. Building. Safety will approve the dress out areas.
2. Personnel are allowed to proceed from the dress out area with safety glasses and safety shoes directly to the elevator.
3. Personnel will don a hard hat upon entering the contaminated area boundary and wear the hard hat while in containment (personnel may wear their assigned hard hat).
4. Personnel are to leave hard hats in the radiological area upon exiting containment and proceed through the step-off pads down the stairs directly to RP access.
5. This applies to all personnel entering the aux. building for access to the containment building.
6. Any personnel entering the aux. building for other reasons shall wear the basic PPE.

### PPE Table

The following table specifies minimum PPE requirements for work activities. If work activity is not listed on the table, or cannot be followed as written, consult your supervisor for specific PPE requirements.

Work Activity	Eye/Face	Foot	Body	Gloves
Abrasive Wheels & Tools (cutting, sanding wood or similar material)	Goggles	Safety Shoes	Standard	Minimum ANSI A4 cut resistant
Abrasive Wheels & Tools (Other)	Goggles & Face shield	Safety Shoes	Standard	Minimum ANSI A4 cut resistant
Aerial Work Platforms	Safety Glasses	Safety Shoes	Standard/Fall Protection	As required for task
Batteries (sealed)	Safety Glasses	Safety Shoes	Standard	N/A
Batteries (unsealed)	Hazard Permit	Safety Shoes	Hazard Permit	Hazard Permit
Batteries (adding water or taking hydrometer readings)	Hazard Permit	Safety Shoes	Hazard Permit	Hazard Permit
Blood borne pathogens (clean-up)	Safety Glasses	Safety Shoes	Per DDP-ZZ-03001	
Chemical Handling (Cryogenic Liquids)	Hazard Permit	Hazard Permit	Hazard Permit	Hazard Permit
Compressed Air Cleaning (also see Compressed Air Section)	Goggles & Dust Mask	Safety Shoes	Disposable Coveralls	Minimum ANSI A4 cut resistant
Concrete Drilling/Cutting	Safety Glasses	Safety Shoes	Standard	See footnote <sup>2</sup>
Cutting Tools (box cutters, knives, other cutting tools)	Safety Glasses	Dependent on work area requirements	Standard	Minimum ANSI A4 cut resistant
Electrical (Exposed Energized Conductors)	See Electrical Safe Work Practices Manual (ESWPM)			
Excavations (Work in)	Safety Glasses	Safety Shoes	Standard	As required for task
While using Hand and Portable Power Tools	Safety Glasses	Safety Shoes	Standard	Minimum ANSI A4 cut resistant
Hot Work (Welding)	Safety Glasses & Welding Shield	Safety Shoes	Long Sleeved Shirt or Welding jacket	Welding – Leather
Hot Work (Grinding)	Goggles & Face Shield	Safety Shoes	Long Sleeved Shirt or Welding jacket	Welding – Leather
Hot Work (Brazing)	As required for task	Safety Shoes	Long Sleeved Shirt or Welding jacket	Welding – Leather
Hot Work (Torch Cutting)	#4 or #5 shade eye protection	Safety Shoes	Long Sleeved Shirt or Welding jacket	Welding – Leather
Hydro blasting / Hydro lasing (3000 PSI or greater)	<sup>1</sup> Goggles & Face shield	Safety Shoes	Water Proof	Welding – Leather
Lab Safety (Chemical Labs)	Follow Chemical Hygiene Plan			
Lead Handling	Safety Glasses	Safety Shoes	Standard	Leather
Legionella (Cooling Tower Entry at power, etc.)	Safety Glasses, ½ Face Respirator, HEPA or Type H Filter	Safety Shoes	Standard	Minimum ANSI A4 cut resistant
General material handling: Handling material where potential hazards to hands exist as identified by worker or supervisor. See hazard examples on page 83.	Dependent on work area requirements	Safety Shoes	Standard	Minimum ANSI A4 cut resistant
Nut Splitting	Safety Glasses/Face Shield	Safety Shoes	Standard	Minimum ANSI A4 cut resistant
Rigging Operations	Safety Glasses	Safety Shoes	Standard	Minimum ANSI A4 cut resistant
Work Around Steam (Thermal Burns)	Safety Glasses	Safety Shoes	Standard and Thermal Sleeves	Thermal Gloves

<sup>1</sup> Goggles may be substituted with safety glasses if the chemicals are not in use.

<sup>2</sup> If drilling/cutting concrete to (greater than or equal to) 1½" without a drill stop, wear gloves rated for the highest voltage that may be encountered or ground the housing/frame.

**POWERED EQUIPMENT OPERATION**

Intent	Provide guidelines to reduce the potential for injuries associated with the use of light equipment.
Applicability	Applies to all personnel who use power equipment that is not a licensed motor vehicle such as tractors, bobcats, lawn mowers or other powered lawn care equipment, high lifts, backhoes, etc.
Hazards	Cuts – Bruises – Amputations – Crushing Injuries

**Key Point**

Do not use Powered Equipment if you have not been trained or taught how to use it safely.

**General Safe Work Practices**

1. Ensure the operator’s manual is available and accessible for all personnel who have been assigned to operate equipment. Contact your supervisor for the location of the operator’s manual, if needed.
2. Ensure all equipment meets the manufacturer’s requirements for safe operation. This includes:
  - a. Guards and shields are present.
  - b. Safety interlocks are functional (Dead-man switch).
3. Wear a seat belt, where provided, when operating equipment.
4. Operate all powered equipment within manufacturer’s recommended operating parameters.

**References:**

29CFR1926, Subpart W, Rollover Protective Structures; Overhead Protection  
CR 200000366

**RADIO FREQUENCY HAZARDS (RF)**

Intent	To limit the exposure to RF hazards where RF equipment is installed.
Applicability	Applies to all workers in proximity to posted RF hazards.
Hazards	Exposure to RF Hazards

**General Requirements**

1. Adhere to all RF hazards signage.
2. Contact Network Operations Center (NOC) (x60662) prior to entry to the Turbine Building Roof.
  - a. Remain clear of the yellow exclusion zones on the Turbine Building Roof surrounding the RF producing antenna.
  - b. If access is required in the RF exclusion zone, contact Callaway Energy Center Safety for coordination with the Ameren Federal Communications Commission (FCC) license coordinator for RF monitoring.

**RADIOLOGICAL SAFETY**

Reference APA-ZZ-01004 for Radiological Safety Standards.

**REPORTING OF INJURIES AND ACCIDENT/INCIDENT**

Intent	To provide a mechanism whereby accidents/incidents are investigated to ensure root causes are identified and corrective actions are taken that will prevent recurrence.
Applicability	Applies to all employees at the Callaway Energy Center.
Hazards	N/A

**Key Point**

To know where we need to improve in safety, we need to know what types of incidents we are having.

**General Safe Work Practices**

1. All work-related injuries and illness must be reported to Supervision.
2. Ameren Missouri employees must report injuries to their supervisor in accordance with APA-ZZ-00835, Reporting and Processing of Accidents, Injuries and Illnesses.
3. Contractors may use their own form a copy of which must be sent to the Site Nurse.
4. Callaway Safety Department will ensure the required Ameren Missouri injuries and illnesses are called in to Corporate Claims Management in accordance with APA-ZZ-00835.
5. The Supervisor of the employee MUST initiate a "Condition Report per APA-ZZ-00500 for all work-related injuries and illnesses, including first aid cases.
6. Supervisors must evaluate the injuries and illnesses to determine if immediate corrective action can be taken to prevent a recurrence of or to reduce the potential for another injury or illness.

**Event Review Team (ERT) Requirements**

An ERT will be conducted in accordance with requirements of APA-ZZ-00542.

**Near Miss/Potential Injuries with Potentially Serious Consequences**

When an incident occurs that could have resulted in serious injury but did not (normally referred to as a "near miss" or "close call", a "Condition Report DOCUMENT PER APA-ZZ-00500" must be initiated. The CR must include immediate actions taken to prevent recurrence.

**Very Serious Injuries or Fatalities (SIF)**

A very serious injury is one that is clearly life threatening or which may leave an employee permanently disabled.

**References:**

- APA-ZZ-00835, Reporting and Processing of Accidents, Injuries, and Illnesses
- APA-ZZ-00500, Corrective Action Program
- APA-ZZ-00542, Event Review

**RESPIRABLE CRYSTALLINE SILICA CONTAINING MATERIALS**

Intent	Reduce the potential exposure to Respirable Crystalline Silica to no more than 50µg/m3 8 hour time weighted average.
Applicability	Applies to all work activities that generate dust containing Crystalline Silica.
Hazards	Exposure to Respirable Crystalline Silica

**Key Point**

Crystalline Silica includes Quartz, Cristobalite, and/or Tridymite and is frequently found in concrete, ash, and similar materials.

For all Information concerning Respirable Crystalline Silica refer to Management Instruction ES-REG-215, Respirable Crystalline Silica found on Scholar under Safety.

For all information related to Concrete Drilling/Cutting reference EDP-ZZ-04050, Civil/Structural Activities.

**References:**

29CFR1910.1053, Respirable Crystalline Silica

29CFR1926.1153, Respirable Crystalline Silica

ES-REG-215 – Respirable Crystalline Silica

EDP-ZZ-04050, Civil/Structural Activities

**RESPIRATORY PROTECTION**

Intent	To provide a reference to the Callaway Energy Center Respiratory Protection program and to provide specific guidance for some routine respiratory hazards encountered by employees.
Applicability	All employees at the Callaway Energy Center
Hazards	Dusts – Vapors – Mists – etc.

**Key Point**

The primary objectives of the Callaway Energy Center Respiratory Protection Program are to control internal radiation exposure and to protect personnel in hazardous atmospheres.

**General Information**

1. The Callaway Energy Center Respiratory Protection Program is located in APA-ZZ-01000, Health Physics Program, Section 2.2, Respiratory Protection.
2. The objectives are normally accomplished by the application of engineering controls such as process, containment, and ventilation equipment. When such controls are not feasible or cannot be applied, the use of respiratory devices may be appropriate.
  - a. When supplemental ventilation is required for worker protection, Chemistry must be contacted per CDP-ZZ-01100.
3. Guidance for respiratory protection and ventilation when welding and cutting:

**NOTE**

The mechanical ventilation criteria are a minimum ventilation rate of 2,000 cubic feet per minute per welder, or local exhaust ventilation (hood or booth).

- a. Mechanical ventilation is required for general welding and cutting when:
  - 1) In space less than 10,000 cubic feet per welder.
  - 2) In a room with a ceiling of less than 15 feet.
  - 3) In confined spaces or where welding space contains partitions, balconies, or other structural barriers.
- b. Abrasive blasting requires the use of a continuous airflow air-line hood.
- c. Welding in Confined Spaces requires mechanical ventilation. If unable to provide mechanical ventilation, an airline respirator is required.
- d. Welding or cutting on zinc (galvanized) containing material requires mechanical ventilation. If unable to meet ventilation requirements, respirator use is required.

**NOTE**

If the lead based paint is removed 4 inches from the areas of welding/cutting then ventilation requirements default to that of the base metal and rods.

- e. Welding or cutting on lead base materials or materials with lead base paint requires local exhaust ventilation. If unable to provide local exhaust ventilation, an airline respirator is required.

### Step 3 Cont'd

- f. Performing hot work on stainless steels requires mechanical ventilation. See the Safety Department Web Page for details on potential chromium VI exposure.
- g. When performing hot work on Cadmium containing materials, local exhaust ventilation or airline respirator is required.

### Grinding

#### CAUTION

Guidance can be found in APA-ZZ-01000, CDP-ZZ-01100, HTP-ZZ-01201, and HDP-ZZ-08000. You should always contact either Health Physics or Chemistry Department personnel before starting any work that may be subject to or cause a hazardous atmosphere.

- 1. Black Iron or Carbon Steel
  - a. Respirator not normally required for intermittent short duration grinding.
  - b. Respirators required for extended or prolonged grinding.
  - c. Respirators required if respiratory discomfort is experienced.
  - d. Respirators required if visible smoke and fumes is generated.
- 2. Unknown Surface Coatings, Galvanized Metal
  - a. Respirator not normally required for grinding of < 0.5 square foot per day in good ventilation.
  - b. All other grinding requires local exhaust ventilation or respirator.
- 3. Cadmium Containing Metals
  - a. Must wear respirator at all times or local exhaust ventilation.
  - b. Follow all provisions of cadmium standard.
- 4. Known Surface Coatings
  - a. Refer to SDS and follow recommendations for respirator use.
  - b. At any time, respiratory discomfort is experienced, contact Chemistry for evaluation of ventilation and/or respirator use.
- 5. Lead Based Paint
  - a. Refer to Corporate Guidance ES-Reg-211 lead found on Co-worker Connect.

#### References:

CR 199900984

APA-ZZ-01000, Health Physics Program

CDP-ZZ-01100, Atmospheric Hazard Control Program

HDP-ZZ-01200, Preparation and Maintenance of General and Specific Radiation Permits

HDP-ZZ-08000, Respiratory Protection Program

Safety Department Web Page, Hexavalent Chromium Program

**SAFETY MEETING GUIDELINES AND SAFETY COMMITTEE GUIDELINES**

Intent	Provide guidance for Safety Meeting requirements at Callaway Energy Center.
Applicability	All permanently assigned departments at Callaway Energy Center.
Hazards	N/A

**Key Point**  
Increase awareness and knowledge of safety within each department.

**Safety Meeting Guidelines**

1. The meetings should begin with a discussion of any immediate Safety Concerns.
2. Safety Meetings shall be held on a monthly basis unless operational considerations do NOT allow (Refuels/Outages). Quarterly Safety Standdowns will replace the monthly Safety Meetings on scheduled months. Additional Safety Meetings/Standdowns may be held as necessary.
3. Daily work should not be scheduled during the department designated safety meeting timeframe.
4. Presentations/topics should be provided by the Callaway Safety Department/PI Department.
5. Departments should review applicable sections of the Safe Work Practices Manual on an ongoing basis (for example 1-2 sections per month) to ensure personnel are aware of and understand safety requirements.
6. Personnel not in attendance should review the information covered in the Safety Meetings.
7. Meetings should be utilized to discuss new safety equipment available to departments.
8. Departments should use safety resources as necessary (Films, Literature, or Guest Speakers).
9. Departments should communicate topics prior to each meeting.

**References:**

None

**SAFETY STAND DOWNS**

Intent	To provide guidelines for the conduct of Safety Stand Downs
Applicability	All employees at Callaway Energy Center
Hazards	N/A

**Key Point**

Stand Downs should be utilized to draw attention to both positive and negative trends in the area of Personnel Safety.

**General Information**

1. Stand Downs may be initiated by Safety at any time.
2. Prior to Refueling outages, Safety Stand Downs may be conducted with all personnel on site utilizing the following Safety criteria:

**NOTE**

Operating Departments may not be able to free up personnel to accommodate this and should adjust their stand down schedule as necessary.

- a. If possible, they will be held during the first two hours of the shift on the scheduled day for all shifts. (CR 199800640 and 199902170)

**NOTE**

Operating Departments may need to use the Gaitronics and should minimize Gaitronics use during scheduled stand down times.

- b. The Gaitronics should not be used during Stand Downs. If a work group finishes prior to the established time for the Stand Down, they should not use the Gaitronics and should not perform work that would impact other work groups. (CR 199800668)
- c. Departments need to schedule the Stand Down meeting locations well in advance. Some flexibility in the times for the Stand Downs may be needed to utilize rooms outside of the protected area (including the CMB and EOF). (CR 199800893)

**References:**

- CR 199800640
- CR 199800668
- CR 199800893
- CR 199902170

**SCAFFOLDING**

Intent	Ensure personnel are aware of the safe work practices required while working on scaffolding.
Applicability	All employees at the Callaway Energy Center
Hazards	Falling – Slips – Cuts – Collapsed scaffolds

**Key Point**

All Scaffolding must be erected in accordance with MDP-ZZ-S0001, Scaffolding Installation and Evaluation.

**CAUTION**

If the scaffold tag is present and the red portion stating “Do Not Use! Only Installers Allowed on this Scaffold” is present, DO NOT ACCESS THE SCAFFOLD!

**General Safe Work Practices**

1. Prior to accessing scaffolding, ensure it has a completed Scaffold Tag attached and a Shiftly Inspection completed. Follow the instructions on the scaffold tag. Ensure the Shiftly Inspection indicates the scaffold has been inspected for the shift in which the scaffold is to be used. Shifts are defined as 0700 to 1900 and 1900 to 0700.
2. If the scaffold does NOT have a Scaffold tag, or a properly completed Shiftly Inspection, DO NOT ACCESS THE SCAFFOLD.
3. Special personal safety requirements for use of the scaffolding will be listed on the tag.
4. Do not carry tools or materials in your hands when climbing. Use ropes or other methods to lift materials onto the scaffolds.
5. Do not place heavy material such as large valves onto a scaffold unless it has been specifically designed and erected to handle the specific load.
6. Always inspect scaffolding before use.

**NOTE**

*Scaffold builders* may tie off to a horizontal scaffold member as Fall Protection Anchorage Point on *Excel Modular Scaffolding* only per Excel Tech Manual.

7. Scaffold tie-off points for fall protection are on a vertical post at joint with a horizontal member.

## Scaffold Ladders

1. If scaffolds are greater than 35 feet in height, then a rest platform is required at 35 foot intervals
2. Scaffold ladders do not require the use of fall protection for climbing when the climber is below 20 feet.

### Key Point

When ascending/descending fixed, scaffold, or portable ladders where the climber reaches 20 feet or above, from the climbers' feet to the platform/level below, fall protection is required. Fall protection can consist of an installed cage, center ladder safety device, or retractable lanyard.

3. If working off of a scaffold ladder less than 20 feet in height, fall protection is not required unless:
  - a. Working outside the rails of the ladder
  - b. Above handrails
  - c. Over a hazardous process (i.e. open tanks, unguarded moving parts, etc.),
  - d. Leaning back on ladder.

### References:

MDP-ZZ-S0001 – Scaffolding Installation and Evaluation

29CFR1910.28 – Safety Requirements for Scaffolding

29CFR1926.451 – Scaffolds General Requirements

**SHOP SAFETY**

Intent	Provide guidance to remove the potential for injury from hazards associated with machine and fabrication shop work.
Applicability	All employees at the Callaway Energy Center
Hazards	Trips/slips/Falls – Eye Injury – Pinch Points – Lacerations – Burns – Flying Objects – Electrical Contact

**Key Point**

Shop tools must be used by trained/qualified personnel. People not using the shop tools should stay well clear of the work operations.

**General Safe Work Practices**

1. Ensure operators are qualified and/or have demonstrated skills before operating shop tools and equipment.
2. Follow the PPE requirements listed in the PPE section of the SWPM.
3. Inspect machines before use.
4. Immediately remove defective machines from service, tag them with “DANGER - Do Not Use” tags, and do not use them until repaired.
5. Ensure manufacturer’s instructions are available to the user and followed.
6. Before operating equipment, ensure machine guards are in place to protect operator and personnel.
7. Clean machines after use.
8. Do not wear loose clothing including sleeves, gloves, lanyards, jewelry and hoods when performing lathe work (and other work with rotating shop equipment) including contaminated lathe work.

**References:**

INPO Significant Event Notification 192, 2/12/99

**STANDING ON/STEPPING ON PLANT EQUIPMENT**

Intent	To provide guidance for the safety and appropriateness of standing or stepping on plant equipment.
Applicability	Applies to all personnel.
Hazards	Slips – Trips – Falls

**Key Point**

Standing or stepping on plant equipment presents risk to the safety of the individual and the risk of damage to plant equipment.

**NOTE**

Free climbing should only be used when other mitigating actions such as the use of ladders, stands, lifts, or scaffold is not possible or safe to use. Free climbing relies solely on workers behaviors and PPE as working from heights protection.

**General Safe Work Practice**

1. Prior to standing or stepping on plant equipment, the individual must assess the specifics of the work and the location of equipment to determine whether this is the appropriate way to perform the task.
2. If it is determined standing or stepping on plant equipment is the best/safest way to complete the task, then the following must be followed:
  - a. 100% tie off is required when over 4’ above the lower level
  - b. Tools and Equipment are NOT to be hand carried
  - c. Do NOT step on:
    - Snubbers
    - Sensing Lines
    - Insulated Piping
    - Fire Piping
    - Other Sensitive Equipment
  - d. Personnel may only step on equipment that is clearly strong enough to support the weight of the individual
  - e. If unsure of load bearing capabilities, contact your supervisor
3. Jumping or hopping is prohibited from Vehicle Barrier System (VBS) Blocks, pick-up truck beds, flatbed trucks/trailers, ladders, scaffolding, loading docks, and other surfaces of similar height.
4. For additional guidance on fall protection refer to the section of this manual titled “Fall Protection”.

**References:**

None

**TOOL/MATERIAL CONTROL ON ELEVATED WORK AREAS**

Intent	Reduce the potential for tools, materials, and equipment falling to lower levels while working on elevated surfaces
Applicability	Applies to all work activities on platforms (including aerial work platforms), grating, or scaffolds where personnel could walk/pass underneath
Hazards	Fall objects – Injuries – Damage to Equipment – FME Concerns

**Key Point**

When working on platforms, grating, or scaffolds where personnel could pass underneath, the control of tools, materials, and/or equipment **MUST** be controlled to prevent them from falling to lower levels.

**General Safe Work Practices**

1. Tools, materials, and equipment being used, stored, or handled on elevated areas **MUST** be controlled from falling to lower levels.
2. To control tools, materials, and equipment from falling to lower levels, the use of toe boards, netting, floor covers, platforms, and/or lanyards shall be required.

**Aerial Work Platforms and Scaffold Platforms**

When working in aerial work platforms (i.e. JLG's, etc.) the following **MUST** be performed:

1. If tools, material or equipment will be piled higher than the toe boards, then netting **MUST** be installed between the mid-rail and the toe boards on all side of the aerial work platform
2. If handling materials outside of the handrails of the platform, the tool/equipment lanyards **MUST** be used, or barricade the area below to prevent inadvertent access by personnel. Follow the barricade section of the Safe Work Practices Manual or use another person to stop personnel from walking under the area.
3. If work is required to be performed in an area directly below overhead work, then netting or a fully planked platform must be installed between the work overhead and the workers below.

**Permanent Platforms and Working over Grating**

1. When working on an elevated area where there is a potential to drop tools, material, or equipment to a lower level, either off of the edge or through the grating, the following **MUST** be performed:
2. If working over grating, the walking surface must be covered with material that will not allow tools, equipment, or other materials to fall through the grating to lower levels (e.g. plywood, rhino-rug, etc.)
3. Toe boards must be installed on the edges of the platforms. If toe boards are not already installed, then temporary toe boards **MUST** be installed prior to staging material, tools, or equipment and prior to starting work performance.
4. If the tools, material, or equipment will be piled higher than the toe boards, then netting **MUST** be installed between the mid rail and the working surface of the platform.
5. If handling materials outside of the hand rails of the platform, the tool/equipment lanyards **MUST** be used, or barricade the area below to prevent inadvertent access by personnel. Follow the barricade section of the Safe Work Practices Manual or use another person to stop personnel from walking under the area.
6. If work is required to be performed in an area directly below overhead work, then netting or a fully planked platform must be installed between the work overhead and the workers below.

**Lanyards**

Lanyards must meet the following requirements:

1. Support the weight of the tool
2. Not cause injury to the user
3. Be tied off to a solid anchorage point
4. Be appropriate for the work activity (i.e. non-conductive for electrical work, etc.)
5. Be securely attached to the tool

**References:**

None

**VEHICLE SAFETY**

Intent	Provide guidelines to reduce the probability of injuries associated with motor vehicles.
Applicability	Applies to all motorized vehicles used and transport personnel or materials.
Hazards	Vehicle Accidents – Personal Injury

**Key Point**  
Vehicle safety responsibility belongs to both pedestrians and drivers.

**General Safe Work Practices for Motor Vehicles**

When riding in or operating a vehicle:

1. If seatbelts are provided, they must be worn.
2. Ride in seats designed and approved for passenger use, unless the vehicle is designed to be driven standing up.
3. Small vehicles such as “golf cart” type vehicles without rollover protection and seat belts are prohibited from being used on site.
4. No passengers are to ride in the beds of trucks, carts, gators, and trailers unless an approved seat with seat belt has been provided.
5. When refueling, turn vehicle ignition off and do not smoke in the immediate area of the vehicle.
6. Vehicles shall have a service brake system and a parking brake system. These systems may use common components and shall be maintained in operable condition.
7. Defects noted during pre-use inspection of vehicles, making it unsafe for further use, must be repaired before operation is resumed.
8. All motor vehicle accidents must be reported in accordance with APA-ZZ-00835, Reporting and Processing of Accidents, Injuries, and Illness.
9. Do not operate motor vehicles inside buildings unless adequate ventilation is provided. If adequacy is in question, contact Chemistry for assistance.
10. Appropriately secure all transported material.
11. No motor vehicle having an obstructed view to the rear may be operated where any employee is exposed to the hazards created by the moving vehicle, unless:
  - a. The vehicle has a reverse signal alarm audible above the surrounding noise level, or
  - b. The vehicle is backed up only when a designated employee signals that it is safe to do so.
  - c. Trucks, Electric Carts, Gators, or similar styles of vehicles designed to carry people and materials that are permanently assigned to Callaway Energy Center must be equipped with backup alarms. (CR 200000366)
12. Vehicle safety responsibility belongs to both pedestrians and drivers. Use designated walkways, where provided, unless a hazard exists in the walkway. This provides a predictable travel path for pedestrians and limits pedestrian movement in driving lanes.
13. Cargo must be secured to prevent cargo from leaking, spilling, blowing or falling from the motor vehicle.
14. Ensure all materials transported on public highways comply with applicable Department of Transportation regulations (DOT).
15. When on public roadways, flag material that extends more than 4’ past the rear or more than 12” over the sides of a vehicle.
16. The vehicle has a reverse signal alarm audible above the surrounding noise level.

17. A spotter or 360 walk around will be required when there is limited visibility to backing up because of configuration of the truck, load, lighting conditions or other.
18. Use wheel chocks on all disconnected trailers to prevent rolling.
19. Safe speeds shall be maintained on Callaway Energy Center property. 20 mph limit outside the PA and 20 mph limit inside the PA. Slower speeds may be required in congested areas or with pedestrian traffic.

### **Multi-Piece or Large Single Piece Rim Tire Safety Precautions**

#### **NOTE**

Passenger Vehicles or Light Trucks with tires marked "P" or "LT" are not used on multi-piece or large single rims and therefore do not have these requirements for inflation. This section applies to the servicing of multi-piece and single piece rim wheels used on large vehicles such as trucks, tractors, trailers, buses and off-road machines. It does not apply to the servicing of rim wheels used on automobiles, pick-up trucks, and vans utilizing automobile tires or truck tires designated "LT". It also does not apply to mules, gators, bicycles, etc.

1. Multi-piece rim (i.e. split rim) and large single rim tires can be very dangerous if not handled properly. At Callaway, we have several types of vehicles and material handlers that have this type of tire rim, and these safety precautions must be followed to ensure personnel safety.
2. If a tire installed on a vehicle is found to be inflated more than 80% of the recommended pressure as marked on the side of the tire:
  - a. This tire can only be inflated by remote control inflation equipment (Special Tool 252) and the operator must be trained on its use.
  - b. This tire can only be inflated to the pressure marked on the side of the tire.
3. If a tire installed on a vehicle is found to be under-inflated at 80% or less than the recommended pressure as marked on the side of the tire:
  - a. This tire must be completely deflated by removing the valve core before removing the wheel from the vehicle.
  - b. This tire must be inflated inside an approved restraining device.
  - c. This tire can only be inflated to the pressure marked on the side of the tire.
4. If a tire installed on a vehicle has obvious or suspected damage to the tire or wheel:
  - a. This tire must be completely deflated by removing the valve core before removing the wheel from the vehicle.

### **Licensed Vehicles**

Do not operate a motor vehicle on public roadways without authorization and a valid driver's license or appropriate DOT classification, if applicable.

### **References:**

29CFR1926.601, Motor Vehicles

APA-ZZ-00835, Reporting and Processing of Accident, Injuries, and Illnesses

29CFR1910.269.P.1.II, Use of vehicles at off highway job Sites

CR 200000366

**WEATHER**

Intent	Provide guidance for performance of work under adverse working conditions.
Applicability	Applies to all workers who perform work at Callaway Energy Center.
Hazards	Tornadoes – High Winds – Thunderstorms

This SWPM section establishes the method for responding to severe thunderstorm watches, thunderstorm warnings, high winds, tornado watches, or tornado warnings. This SWPM section also establishes the means of notifying plant workers of severe weather and the response of plant workers to severe weather.

**DEFINITIONS**

1. **Approaching** (severe levels) – A thunderstorm which contains winds of 40 to 57 mph, or hail ½ inch or larger but less than ¾ inch in diameter. (The term 'threatening weather conditions that could generate missiles' is from Tech Spec Bases 3.9.4 and equates to approaching severe levels).
2. **Funnel Cloud** – A condensational funnel extending from the base of a towering Cumulus or Cumulonimbus cloud (Cb), associated with a rotating column of air that is not in contact with the ground (and hence different from a tornado).
3. **High Winds** – Winds in excess of 40 mph (18 m/s) sustained, or 58 mph (26 m/s) gusting.
4. **National Oceanic and Atmospheric Administration (NOAA)** – an organization of the U.S. Commerce Department NOAA’s National Weather Service keeps a round-the-clock vigil on atmospheric conditions and issues watches and warnings for severe atmospheric conditions. A weather radio which can receive NOAA weather announcements is located in the Control Room, in the Shift Manager's office, and is activated when local severe weather conditions exist.
5. **Severe Thunderstorm** – A thunderstorm which produces tornados, hail 0.75 inches or more in diameter, or winds of 58 mph or more. Structural wind damage may imply the occurrence of a severe thunderstorm. See approaching (severe).
6. **Thunderstorm** – Rain clouds producing lightning.
7. **Tornado Watch** – Identifies an area where conditions are favorable for a tornado formation.
8. **Tornado Warning** – A tornado warning means that a tornado has been sighted or indicated by weather radar.
9. **Tornado** – A violently rotating column of air in contact with the ground and extending from the base of a thunderstorm. A condensation funnel does not need to reach to the ground for a tornado to be present; a debris cloud beneath a thunderstorm is all that is needed to confirm the presence of a tornado, even in the total absence of a condensation funnel.
10. **Warning** – Issued by NWS local offices indicating that a particular weather hazard is either imminent or has been reported. A warning indicates the need to take action to protect life and property. The type of hazard is reflected in the type of warning (e.g. tornado warning, blizzard warning).
11. **Watch** – A National Weather Service (NWS) product indicating that a particular hazard is possible (i.e. conditions are more favorable than usual for its occurrence). A watch is a recommendation for planning, preparation, and increased awareness (i.e. to be alert for changing weather, listen for further information, and think about what to do if the danger materializes).

## RESPONSIBILITIES

1. **Department Heads and Supervisory Personnel**  
Responsible for ensuring that personnel performing work at locations outside the range of plant announcements are notified of severe thunderstorm watches, thunderstorm warnings, high winds, tornado watches, or tornado warnings, if possible. Areas of concern include:
  - a. Personnel in vehicles
  - b. Personnel performing work in remote locations
  - c. Storeroom 2 level 'A' and 'B' storage
  - d. Restroom facilities
2. **Administration Department**  
Administration ensures that updated copies of Attachment 1, Tornados, are posted and remain visible on plant bulletin boards.
3. **Plant Employees**
  - a. Plant employees are responsible for following the protective action recommendations made over the Gaitronics.
  - b. Plant employees have the responsibility to become familiar with the location of designated shelters, or actions to be taken should these shelters not be readily accessible. Locations and actions are listed below.
4. **Notification and Protection of Plant Personnel**
  - a. When weather conditions for Callaway County broadcasted over the NOAA weather radio report thunderstorm watches and warnings, high winds, and tornado watches and warnings, plant personnel must be notified.
  - b. When thunderstorm or tornado warnings are in effect for Callaway County, outside work should be suspended until the warning is no longer in effect.

## TORNADOES!!

1. When a tornado warning is announced over the Gaitronics, follow instructions in the announcement.
2. If time allows, a safer location (i.e. concrete building) may be used. However, do not take a chance if weather is severe!
3. If you are responsible for people in outside areas or in trailers, attempt to contact them.
4. Avoid the use of elevators.
5. Close all doors between your shelter location and outside areas (including hallway and room doors).
6. Stay away from windows.
7. Go to an inside room and get under a desk or table if you cannot reach your designed shelter area prior to arrival of dangerous weather.

<b>OPERATIONS SUPPORT FACILITY:</b>	Go to the ESW Pump House Plant South section office area.
<b>CALLAWAY LEARNING CENTER:</b>	Room 555 Engineering Classroom, Room 510 File Room, Room 514 Copier Room, Rooms 513 and 515 Restrooms
<b>CALLAWAY MULTI-PURPOSE BLDG:</b>	First floor interior hallways, bathrooms, and locksmith area
<b>CENTRAL PROCESSING FACILITY:</b>	Inner hallways, bathrooms. (Note: Building has a metal roof, stay low, and cover head).
<b>EMERGENCY OPERATIONS FACILITY:</b>	All areas other than near outside doorways
<b>MAIN ACCESS FACILITY:</b>	Go to Main Access Facility basement
<b>OUTAGE MAINTENANCE FACILITY:</b>	Go to the ESW Pump House Plant South section office area.
<b>POWER BLOCK:</b>	Auxiliary, Radwaste, Diesel, and Control Buildings
<b>RP CALIBRATION FACILITY:</b>	Go to the ESW Pump House Plant South section office area.
<b>SECURITY OFFICES:</b>	Go to the Technical Support Center

<b>SERVICE BUILDING:</b>	<p><b>First and second floor personnel:</b></p> <ul style="list-style-type: none"> <li>▪ West corridor, Work Control Offices, Restrooms and Locker rooms, Room 105 (reprographics behind the QA wall).</li> </ul> <p><b>Third floor personnel and NRC offices:</b></p> <ul style="list-style-type: none"> <li>▪ East corridor, NRC offices, Telephone Rooms</li> </ul>
<b>STOREROOM No. 1:</b>	QA Non-Conforming Storage Temperature and Humidity Control Room (Note: Building has a metal roof, stay low, and cover head).
<b>STOREROOM No. 2:</b>	Restrooms in office complex
<b>TECHNICAL SUPPORT CENTER:</b>	All areas other than near outside doorways
<b>TRAINING CENTER:</b>	Lunch Room, Rest Rooms, Classrooms 120/122
<b>TURBINE BUILDING:</b>	Cold Lab, Aux Feed Pump hallways and room, Health Physics Access Control Area
<b>WORK MANAGEMENT BUILDING:</b>	Go to the first floor restroom area or Room 105 of the Work Management Building
<b>ALL OTHER AREAS:</b>	Go to the nearest shelter area, if one can be reached quickly (30-60 seconds). Otherwise take immediate cover in a concrete structure, below ground level area, in the center of a room, or underneath a heavy object such as a desk or table.
<b>IF CAUGHT OUTSIDE AS A LAST RESORT:</b>	Take shelter in the nearest ditch or ground depression. Always cover your head - Remember, most tornado fatalities are from injuries to the head.

**NEVER REMAIN IN TRAILERS OR VEHICLES**

**CALLAWAY LIGHTNING PERSONNEL SAFETY PLAN**

The purpose of this Lightning Safety Plan is for proper monitoring and awareness/response for personnel who are working in area(s) exposed to lightning hazards.

**Lightning:**

Employees need to check weather reports prior to starting outdoor work to be aware of any potential weather hazards (thunderstorms) that may develop during the evolution of work.

At the first sight of lightning, employees working in outside areas exposed to lightning hazards should notify their supervisor. The supervisor (or appointed designee) will assess the situation and monitor utilizing a lightning detector (can be checked out from Service Building (SB) Tool Room). If lightning is detected within 10 miles or the NOAA has issued a thunderstorm warning for Callaway County, work should stop and be placed in a safe condition, seek shelter immediately and await further instructions from their supervisor or Gaitronics announcements.

If personnel are working in outside areas exposed to lightning hazards during an un-forecasted pop-up thunderstorm, they should follow the Flash-to-Bang method. The Flash-to-Bang method is as follow: count the number of seconds from the time that lightning is sighted until a clap of thunder is heard. DIVIDE this number by 5 to obtain how far away (in miles) the lightning has struck. The co-workers should stop work and place in a safe condition, seek shelter immediately and notify their supervisor is the determined distance is 10 miles or less.

When the decision has been made to halt or suspend outside work activities because of lightning, the Control Room (during online) or Outage Control Center and Maintenance Control Center (during outages) must be notified by the supervisor (or appointed designee). Once the storm has safely moved out of the area and associated lightning activity is no longer present the supervisor (or appointed designee) will once again contact the Control Room (during online) or Outage Control Center and

Maintenance Control Center (during outages) to notify work is resuming. The supervisor (or appointed designee) will then communicate this to all Co-Workers associated with the work activity.

(Note: All outdoor work-related movement during thunderstorms with lightning within 10 miles should be limited to essential personnel for nuclear safety operations only.)

**WORKMAN’S PROTECTION AND FACILITIES LOCK-OUT**

Intent	To provide general guidance on the use of WPA and Facilities Lock-Out.
Applicability	Applies to all employees, vendors, and contractors.
Hazards	Electrocution – Moving Equipment

**Key Point**

WPA does NOT take the place of the individuals' own SAFE WORK HABITS, nor does it relieve the WPA User of the responsibility of determining if SAFE WORK CONDITIONS exists.

The control of hazardous energy sources is accomplished in accordance with APA-ZZ-00310, Workman’s Protection Assurance and APA-ZZ-00314, Facilities Lock-Out.

**References:**

APA-ZZ-00310; Workman's Protection Assurance

APA-ZZ-00314; Facilities Lock – Out