

**BTM VOLTAGE MONITORING OF THE 2 EXISTING SOLAR ARRAYS WITH TWO SETS OF PT'S THROUGH ONE 3PDT RELAY TO A SINGLE METER.**

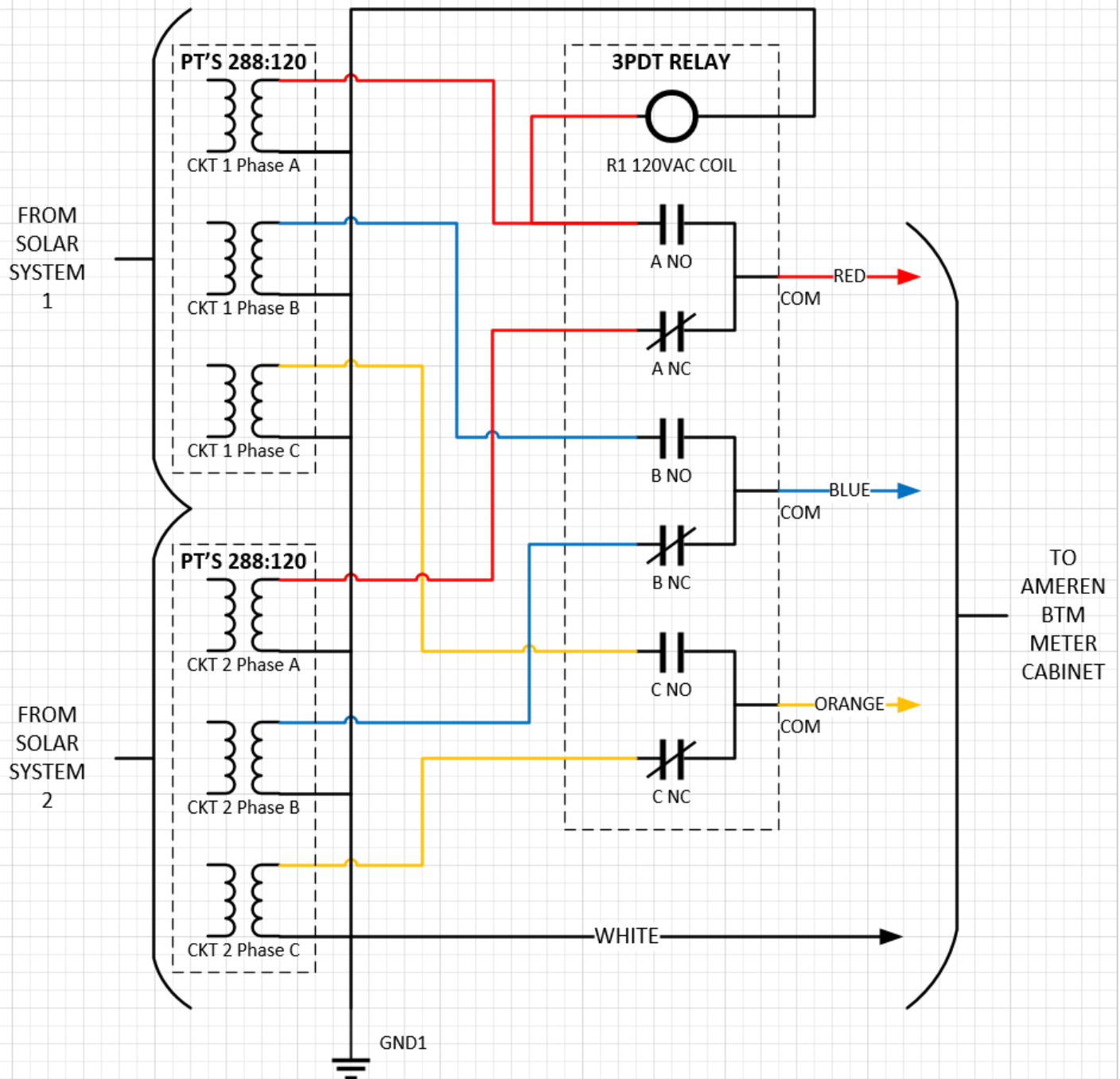

3PDT = Three Pole, Double Throw relay.

Relay connections are usually labelled COM, NC and NO:

COM = Common will be connected to the meter.

NO = Normally Open, COM is connected to this when the relay coil is on (System/Circuit 1).

NC = Normally Closed, COM is connected to this when the relay coil is off (System/Circuit 2).